



ESTRONTM

ESTRON MARKETING PTE. LTD.



PerMat
PERFECTMATCHSYSTEM

MD60-L/R ULTRA SLIM MARVAL DOOR



PRODUCT FEATURES

Estron Marval Trackless Sliding Door showcases an **ultra slim profile** that elevates gorgeously on most modern interior design with effortless sophistication. Designed as a “ghost” door, it glides smoothly **without visible tracks**, creating a striking **floating effect** that enhances the sense of space and openness.

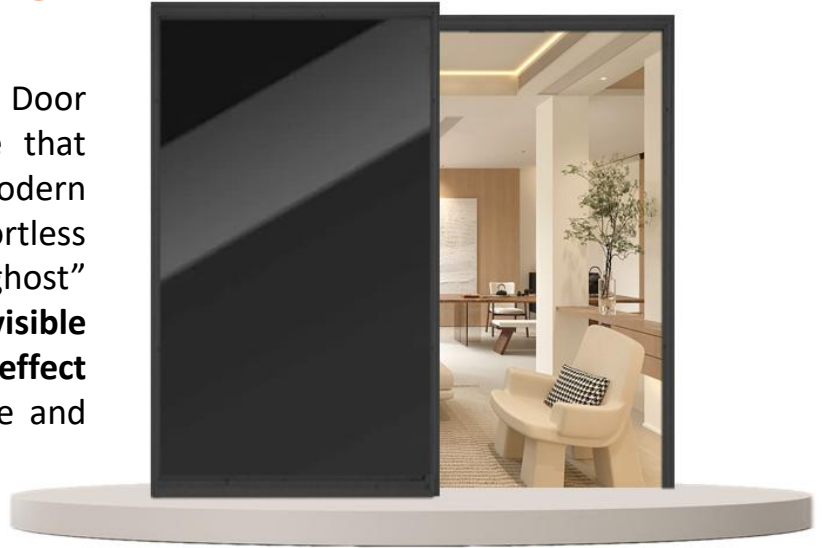

With its sleek 16mm x 42mm frame, this system embodies true minimalism. Clean lines, reduced visual clutter, and a refined architectural presence. Perfect for contemporary homes, offices, or stylish commercial spaces, it seamlessly blends form and function while delivering quiet, smooth operation.

“TRACKLESS, NO CLUTTER. JUST ULTRA-SLIM “FLOATING” DOOR WITH SLEEK & MODERN AESTHETICS”

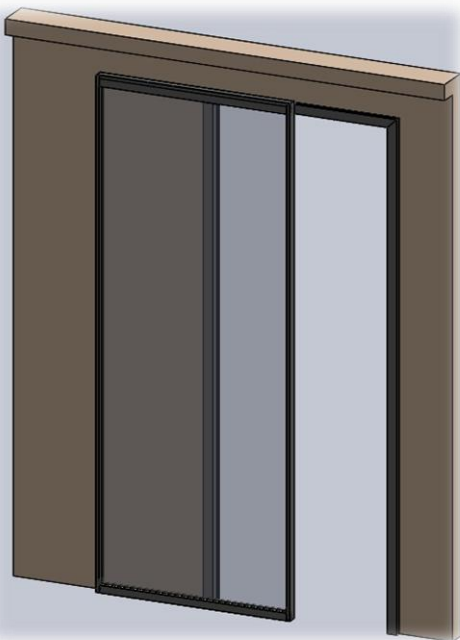

KEY FEATURES

A statement of subtle elegance, the Marval (MD-60) Trackless Sliding Door brings a minimalist yet distinctive touch to any interior.

- **Matte Black Finishes**
- **8mm-11.52mm** Glass Thkness/**50kg** per panel
- Ultra Slim Profile **16mm x 42mm**
- Featuring **Trackless & Sleek** Contemporary aesthetics
- Optimal for **residential or offices**
- **Soft closing** mechanism
- **Left or Right** Configuration



PRODUCT SPECIFICATIONS

A removable section in the **top** rail ensures easy access for maintenance, repairs, and part replacements.

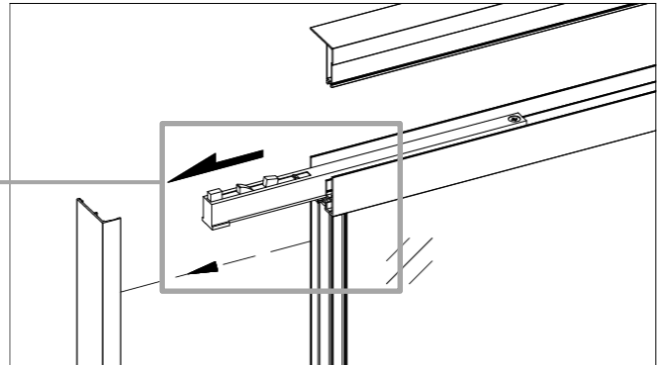

A removable section in the **bottom** rail ensures easy access for maintenance, repairs, and part replacements.

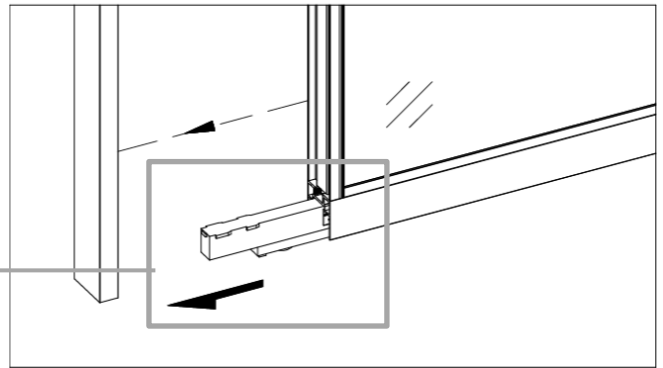

Model	Description
Panel Configurations	Single Panel
Track Length	NIL
Finishing	Matte Black
Door Width	600mm ~ 1000mm
Door Weight	Max. 50kg
Door Height	Max. 2800mm
Door Frame Thickness	42mm
Glass Thickness	8mm-11.52mm
Wall Overlapping	43mm
Soft Closing	Two-way Soft Closing
Door Opening	561mm ~ 961mm
Clear Entry	514mm ~ 914mm



TECHNICAL DRAWINGS

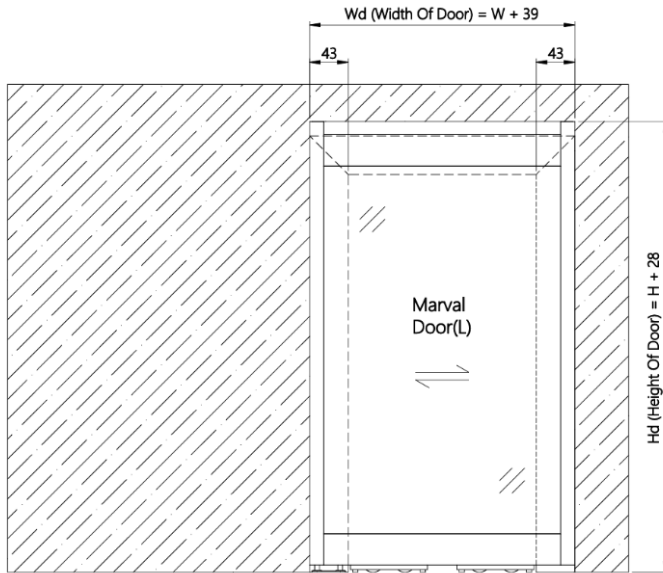

1) The final door size is determined by the entrance opening, factoring in the required wall overlap and the necessary clearance between the ceiling and the top of the door.

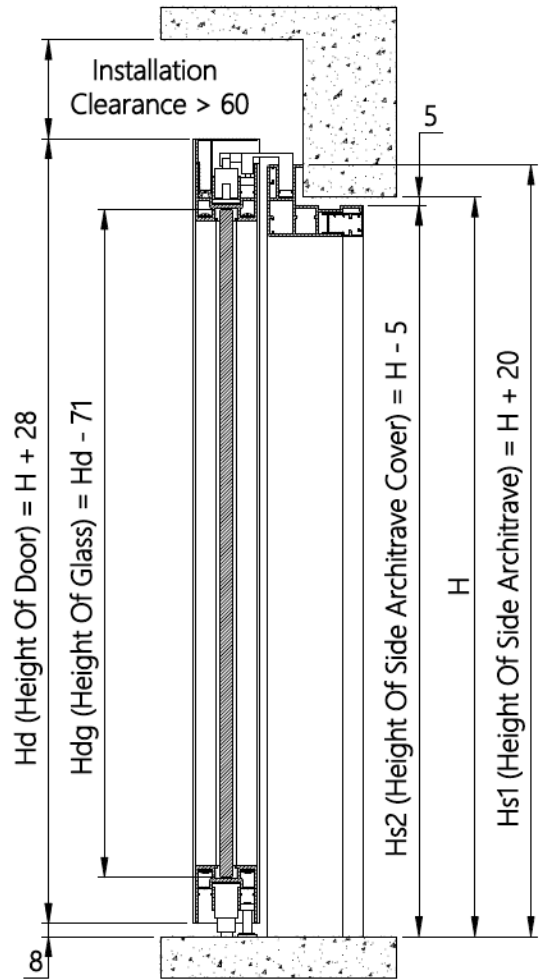

Sectional Details

Important Installation Notes

The surface of the floor should be even, with a maximum deviation of 2mm.

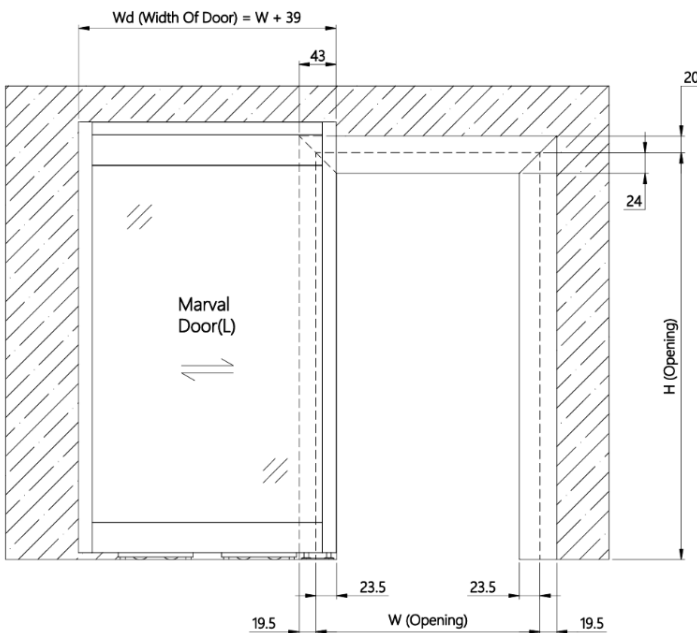

2) Technical drawing of an open door.



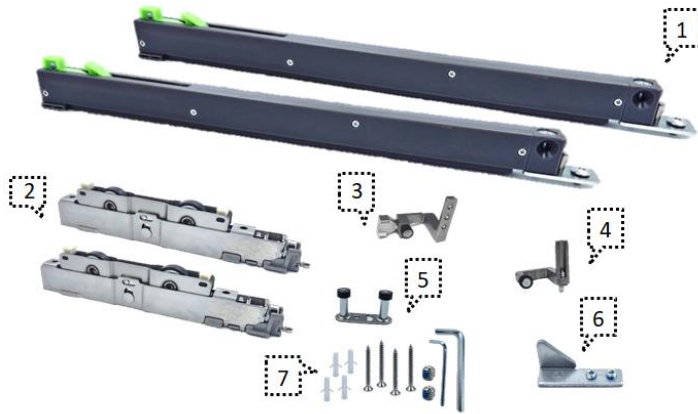

COMPONENT LIST

MD-60-L Marval Door

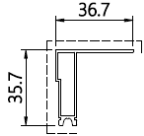
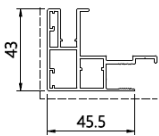
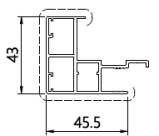
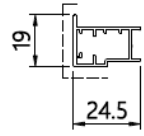
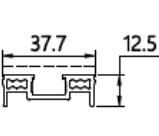
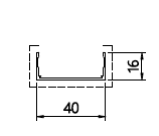
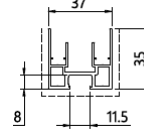
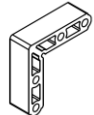

1. Soft Closing Damper Unit, 2nos
2. Floor Roller Guide, 2nos
3. Roller Guide 1 c/w Activator, 1no
4. Roller Guide2, 1no
5. Floor Guide, 1no
6. Bracket (L), 1no
7. Screw Pack, 1 Set

ADDITIONAL COMPONENT LIST

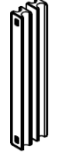
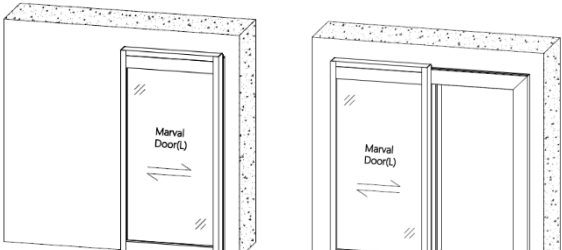
 <p>1. STC82-3736 Top Rail Frame Cover</p>	 <p>2. STC82-4643 Invis Sliding System</p>	 <p>3. STC82-4643H Stile Wall Frame Heavy Duty</p>
 <p>4. STC82-2519 Outer Wall Frame</p>	 <p>5. STC82-3812 Outer Wall Frame</p>	 <p>6. STC82-4016 Stile Frame Cover</p>
 <p>7. STC82-4016 Top & Bottom Door Rail</p>	 <p>8. MD60-B1 Bracket Architrave 1</p>	 <p>9. MD60-B2 Bracket Architrave 2</p>
 <p>10. SDH-1815 Matte Black Handle</p>		



Estron Marketing Pte. Ltd.

141 Woodlands Industrial Park E5 E-terrace Singapore 757507

tel. +65 6853 9041 fax. +65 6853 9042

e-mail. sales@estron.com.sg url. www.estron.com.sg



*Product improvement is a continuous process,
please check specifications at point of purchase.*