

ESTRON
MARKETING PTE. LTD.

SLIDING-STACKING SS-100
WOODEN / ALUMINUM DOOR



®

ESTRON

T: +65 6853 9041 | F: +65 6853 9042

www.estrone.com.sg

SAFE OPERATION BETTER USER COMFORT MADE TO MEASURE OPTIONS

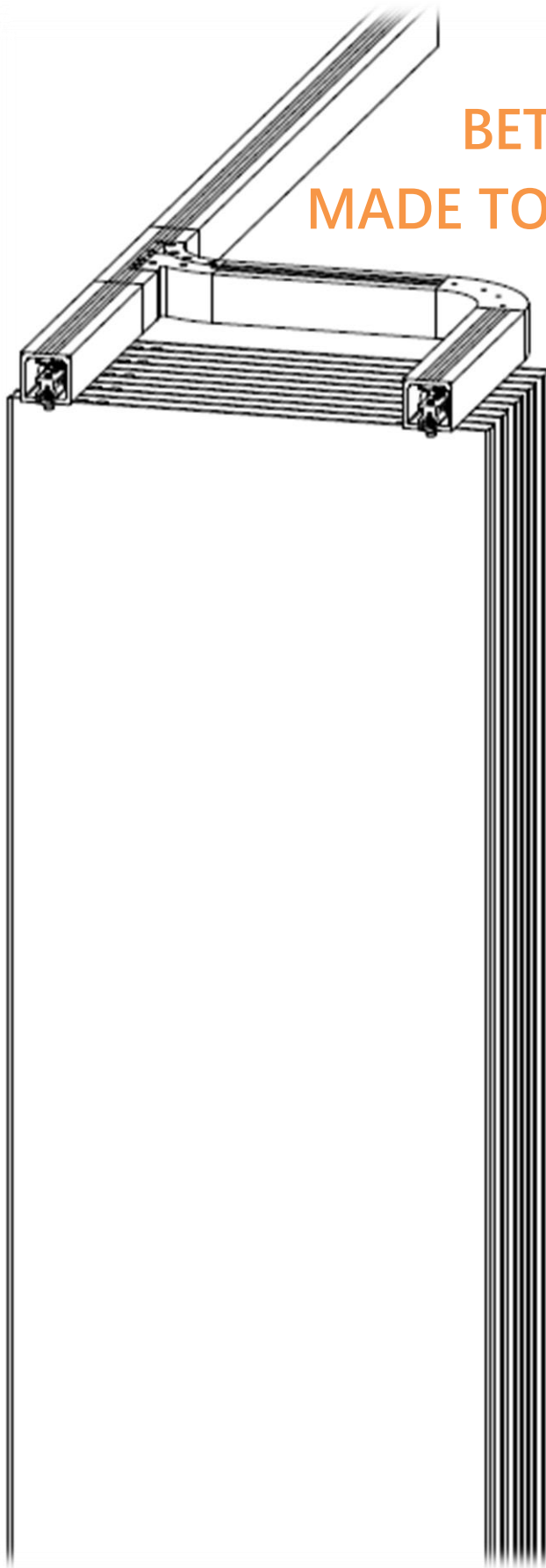

ESTRON Sliding-Stacking Door System is an aluminium track and top hanger system which transport different doors (choice of Wooden / Aluminium / Frameless Glass / Semi-framed Glass) through 45, 90, 135 degree switches for closing off wide opening areas by stacking each panels together in a stacking area called the Parking Bay.

The advantage of this system is that there has no need for a floor guide or channel guide on the floor. Making the frontage look physically appealing and clean even after closing up the system. Therefore, this system is ideally suited for shop fronts, hotels, convention centres, corporate offices and even private houses.

TYPICAL INSTALLATION

ESTRON sliding-stacking systems catered for Wood or Aluminium doors are made up of the following components:

- Top Track for direct mounting to a steel grider (mild steel structures) or directly on a ceiling.
- UC-3245 U-Channel inserted at the Top & Bottom of door to hold parts and accessories for a physically appealing system.
- Specially designed Rollers, Carriers and Carrier profiles that ensure easy sliding with minimum efforts.
- Stacking area called Parking Bay, in which door panels are neatly and compactly stacked and rest in when the system is opened up.

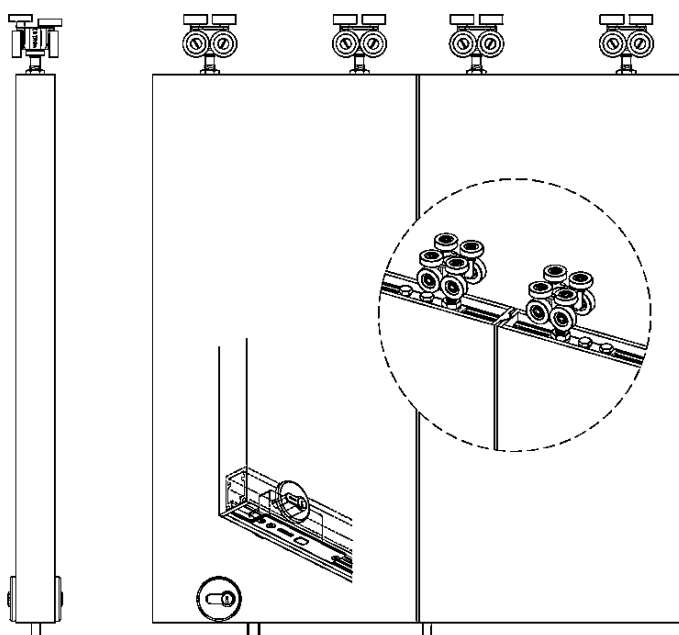

Incorporation of UC-3245 into the wooden sliding

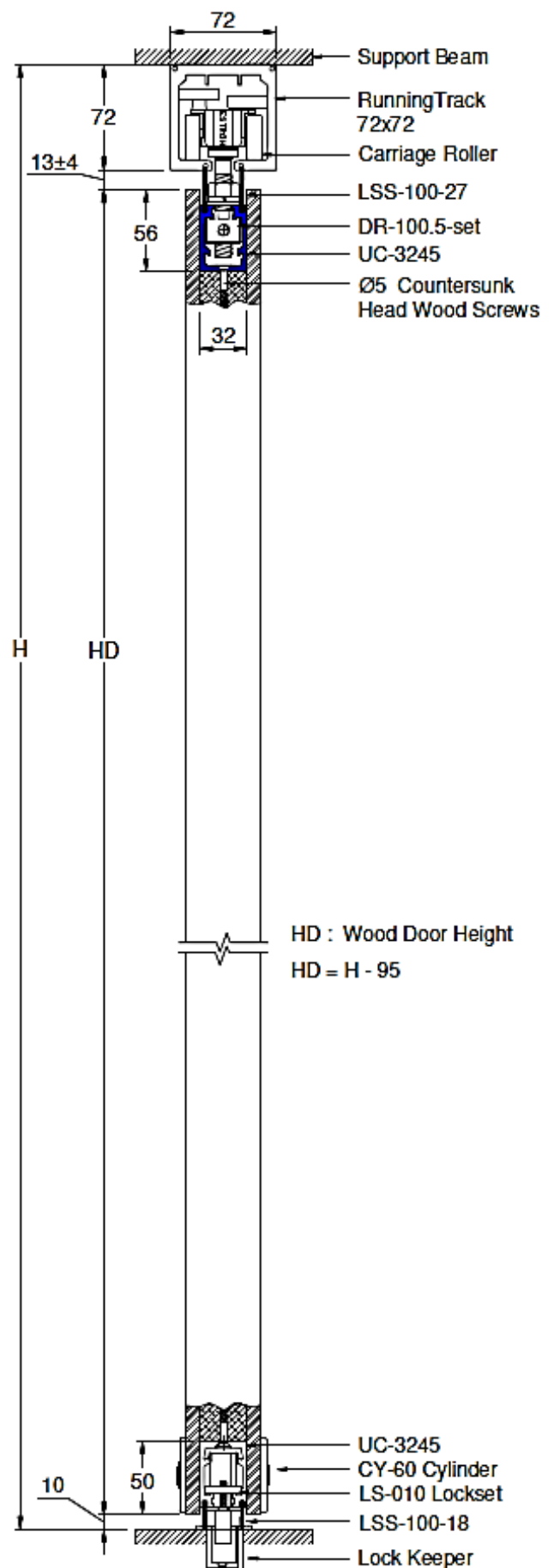

STACKING LAYOUT

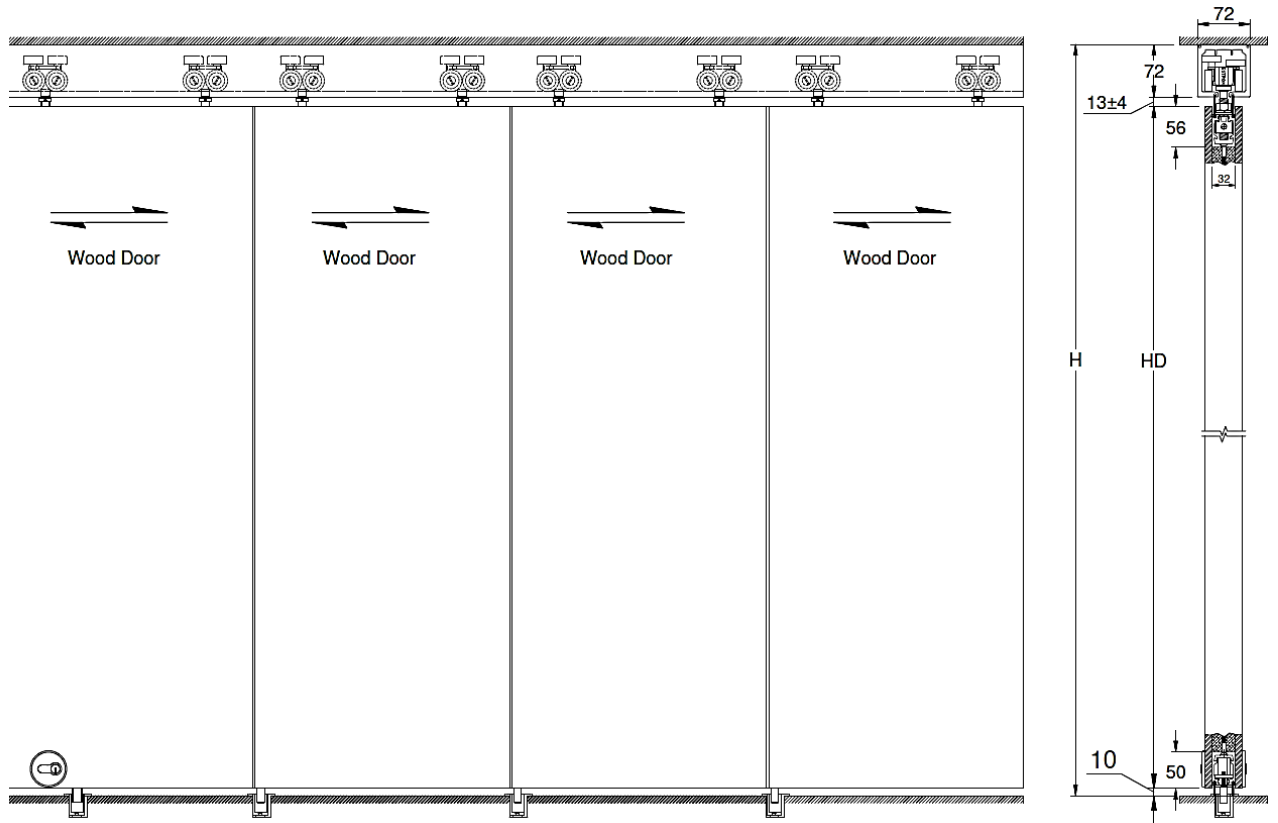

SECTION DETAILS

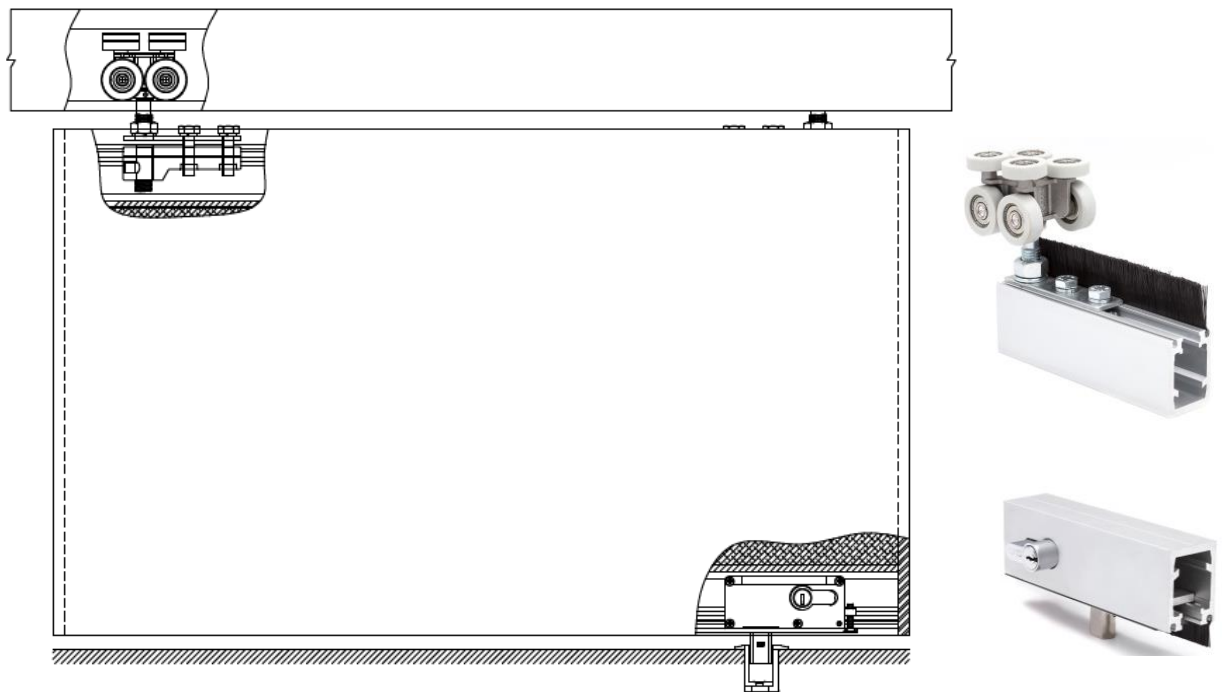

Rollers and Lock inserted into UC-3245 inside Wooden

TYPICAL PARKING CONFIGURATION

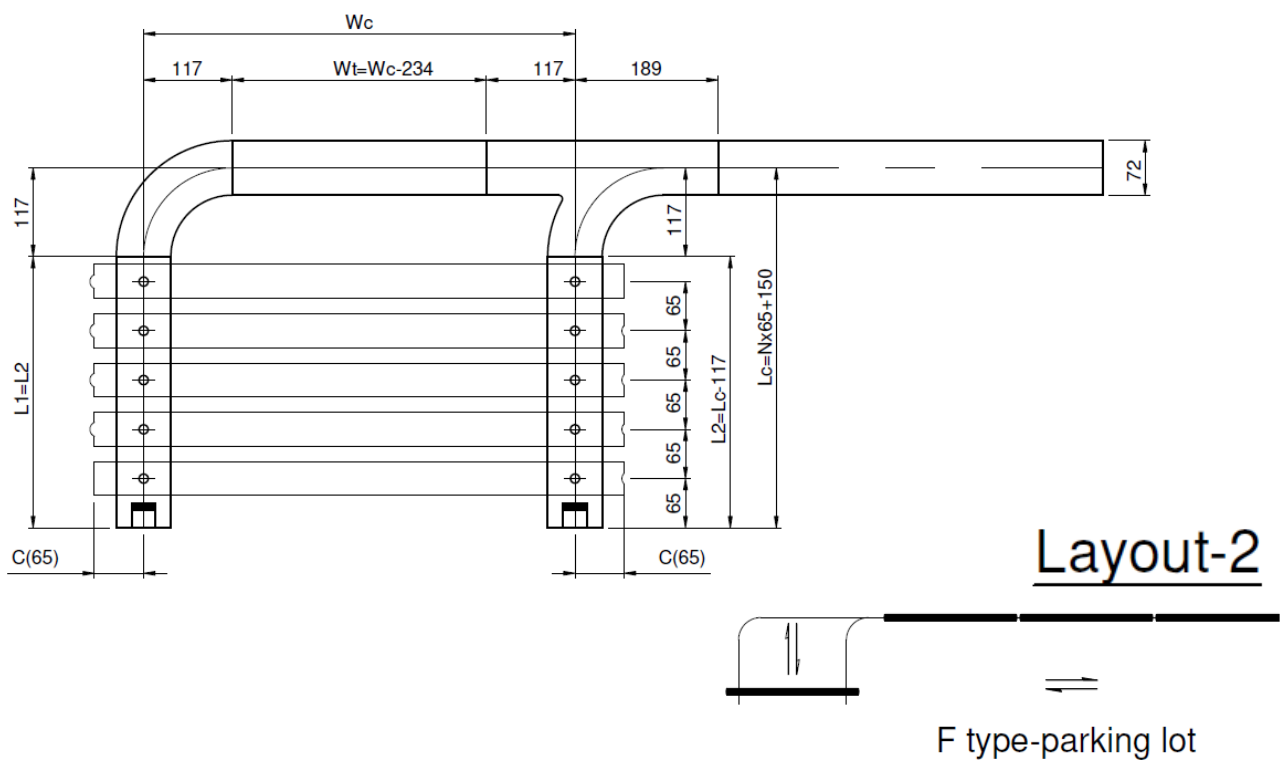
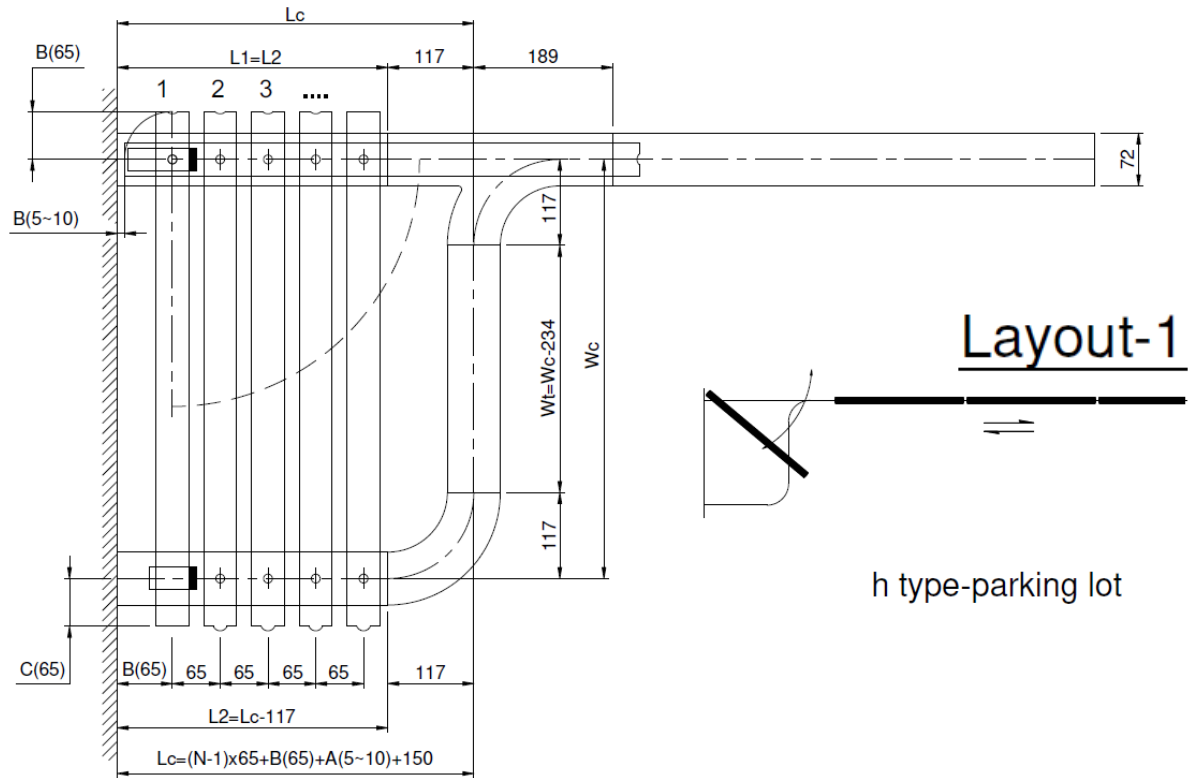

ALUMINIUM TOP TRACK

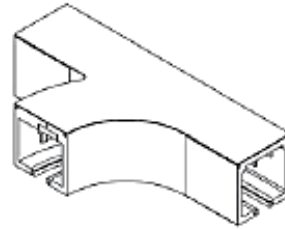
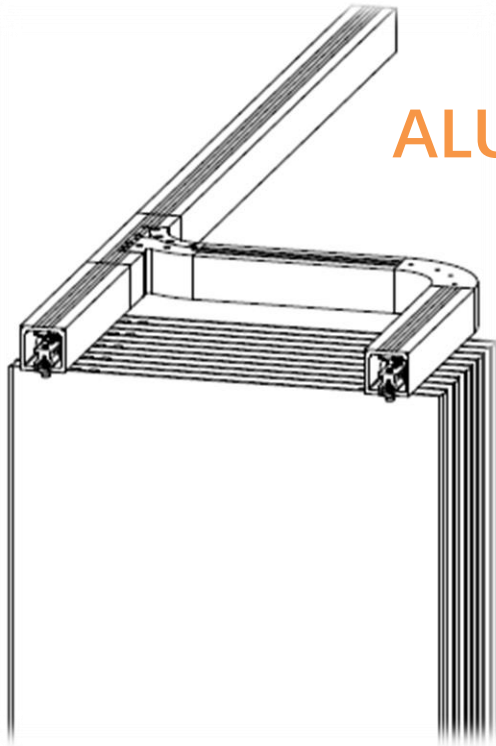

JB-100-90L

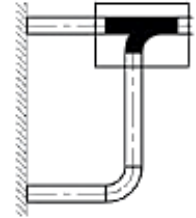

DWG-A

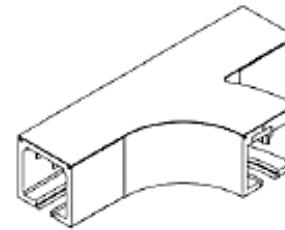

JB-100-90R

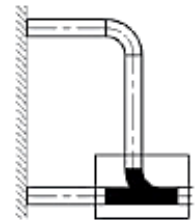

DWG-B

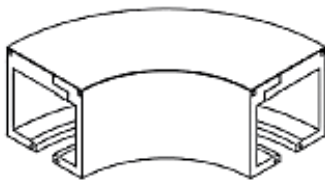

JB-100-L90

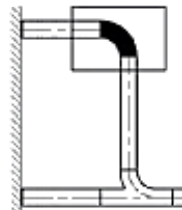

DWG-C

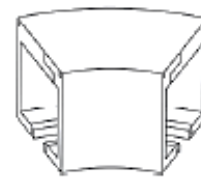

JB-100-45

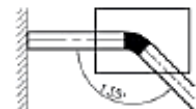

DWG-D

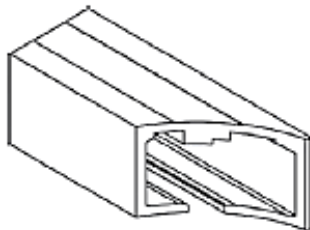

DWG-E

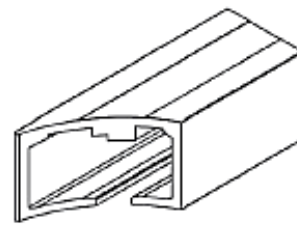
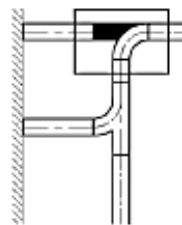

DWG-F

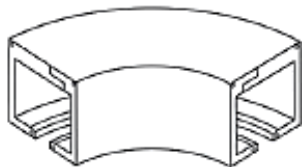
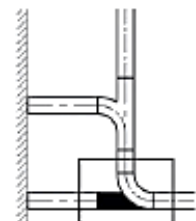

JB-100-L85

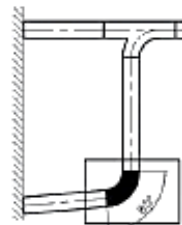

DWG-G

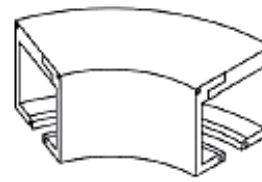

JB-100-L70

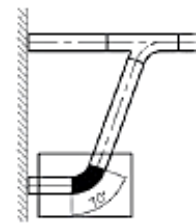

DWG-H

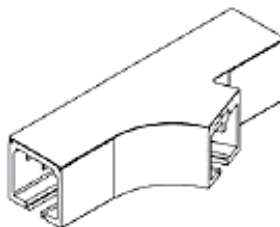

JB-100-110R

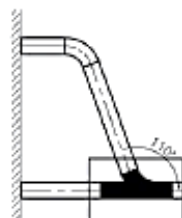

DWG-I

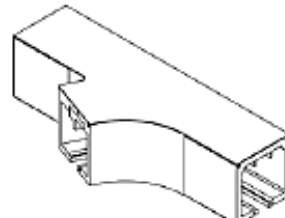

JB-100-110L

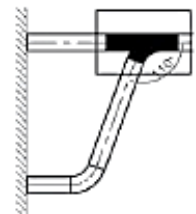

DWG-J