

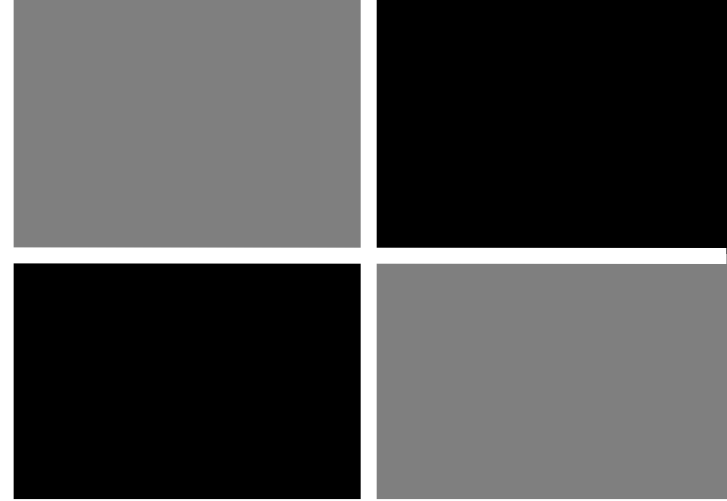

**ESTRON**<sup>TM</sup>

**ESTRON MARKETING PTE. LTD.**



# DOOR HANDLES

*Quality Architectural  
Hardware Specialist*



# PH SERIES DOOR HANDLES

## FEATURES

- Suitable for 8mm to 15.52mm glass thickness
- Glass preparation is required
- Material: SUS304 Stainless Steel
- Finish: Polish (PSS) / Satin (SSS) / **Matte Black (BK)** - Refer to Pg. 10 - 12



PH-00

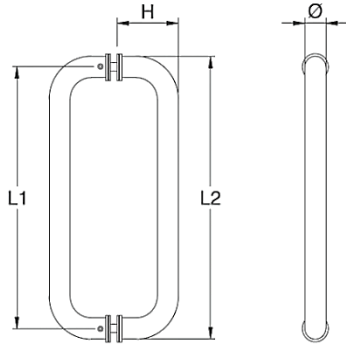

Size in mm

Ø	L1 (C/C)	L2	H	Finish
25	275	300	75	PSS
	305	330	75	PSS/SSS
	425	450	75	PSS
	600	625	75	PSS
32	305	337	75	PSS
	425	457	75	PSS
	600	632	75	PSS

Glass Preparation Ø 12 - 15



PH-01

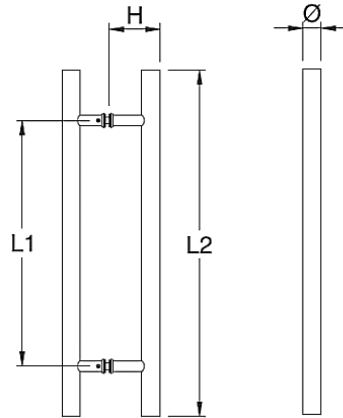

Size in mm

Ø	L1 (C/C)	L2	H	Finish
25	305	425	70	PSS/SSS
	425	600	70	PSS/SSS
	600	900	70	PSS/SSS
	800	1000	70	PSS/SSS
	1000	1200	70	PSS/SSS
	1200	1800	70	PSS/SSS
32	305	500	80	PSS
	425	600	80	PSS/SSS
	600	900	80	PSS/SSS
	800	1000	80	PSS/SSS
	1000	1200	80	PSS/SSS
	1200	1500	80	PSS/SSS
	1800	2200	80	PSS/SSS

Glass Preparation Ø 12 - 15



PH-02

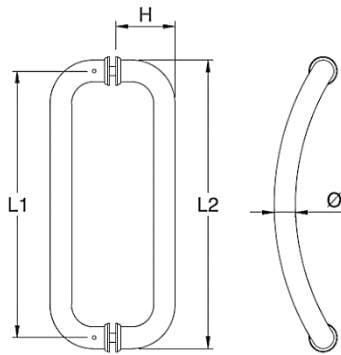

Size in mm

Ø	L1 (C/C)	L2	H	Finish
25	305	330	70	PSS
32	578	610	70	PSS

Glass Preparation Ø 12 - 15

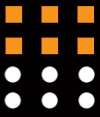

PH-03

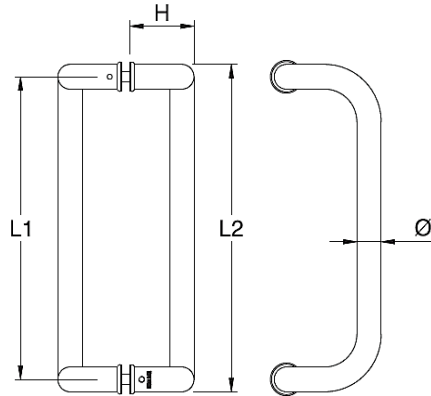

Size in mm

Ø	L1 (C/C)	L2	H	Finish
25	305	330	65	PSS
32	305	337	65	PSS
32	425	457	65	PSS

Glass Preparation Ø 12 - 15



PH-04

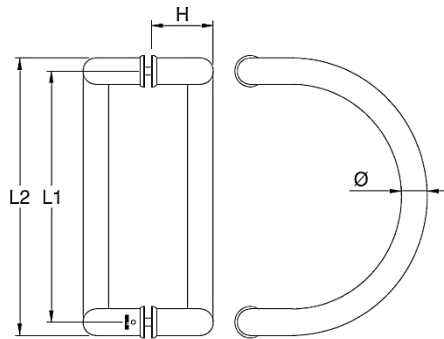

Size in mm

Ø	L1 (C/C)	L2	H	Finish
32	305	337	75	PSS

Glass Preparation Ø 12 - 15



PH-05

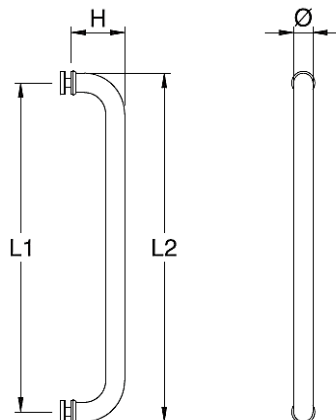

Size in mm

Ø	L1 (C/C)	L2	H	Finish
25	305	330	70	PSS
25	425	450	70	PSS

Glass Preparation Ø 12 - 15



# PH SERIES DOOR HANDLES

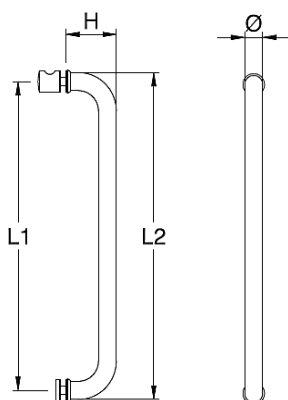

Size in mm

Ø	L1 (C/C)	L2	H	Finish
25	275	300	70	PSS
	305	330	70	PSS
	425	450	70	PSS

Glass Preparation Ø 12 - 15

PH-05-N-800

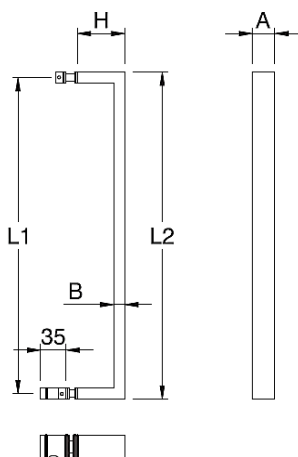

Size in mm

A	B	L1 (C/C)	L2	H	Finish
30	15	425	440	70	SSS

Glass Preparation Ø 12

PH-05R

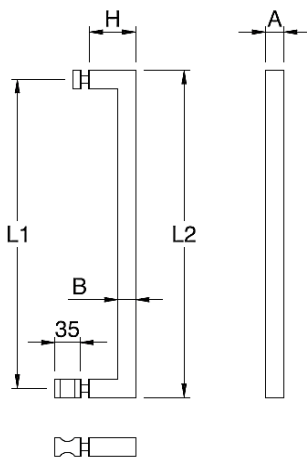

Size in mm

A	B	L1 (C/C)	L2	H	Finish
19	19	425	444	60	PSS/ SSS

Glass Preparation Ø 12

PH-05S



# PH SERIES DOOR HANDLES

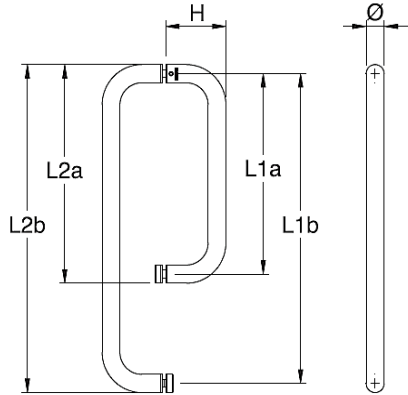

Size in mm

Ø	L1a (C/C)	L1b (C/C)	L2a	L2b	H	Finish
25	275	425	300	450	70	PSS/SSS
25	275	575	300	600	70	SSS

Glass Preparation Ø 12 - 15

PH-06

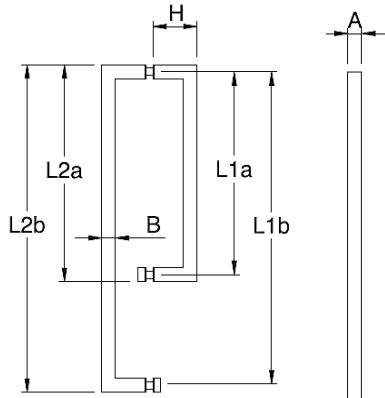

Size in mm

A	B	L1a (C/C)	L1b (C/C)	L2a	L2b	H
19	19	275	425	295	445	65

Glass Preparation Ø 12 - 15  
Finish: PSS / SSS

PH-06S

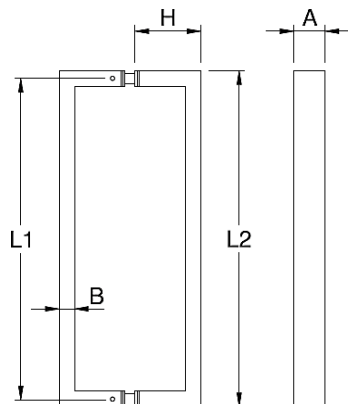

Size in mm

A	B	L1 (C/C)	L2	H	Finish
30	15	305	320	65	SSS
		425	440	65	SSS
		600	615	65	SSS
40	20	1000	1020	70	SSS
		1180	1200	70	PSS/SSS

Glass Preparation Ø 12

PH-00R



# PH SERIES DOOR HANDLES

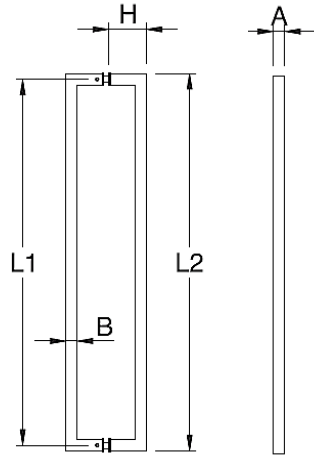

Size in mm

A	B	L1 (C/C)	L2	H	Finish
19	19	425	445	65	PSS/SSS
		600	620	65	PSS

Glass Preparation  $\varnothing$  12 - 15

**PH-00S**

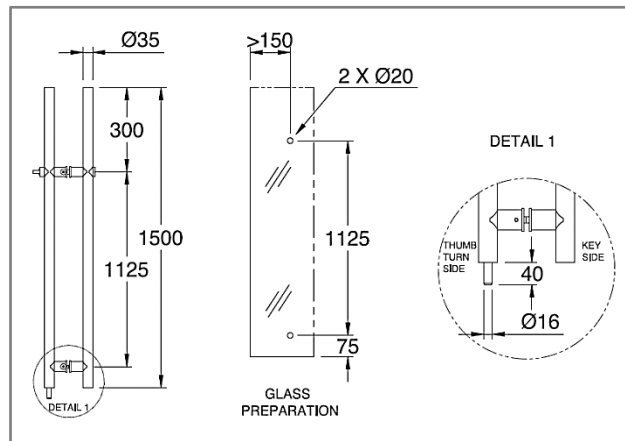

**PH-07**  
Finish: SSS

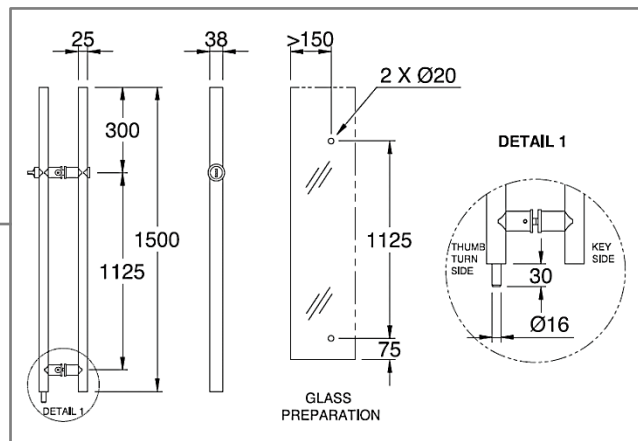

**PH-08**  
Finish: SSS



# PH SERIES DOOR HANDLES

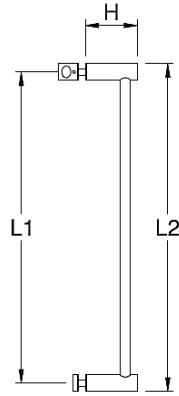

Size in mm

A	B	L1 (C/C)	L2	H	Finish
25	16	475	500	80	PSS

Glass Preparation  $\varnothing$  12 - 15

PH-09

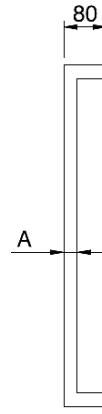
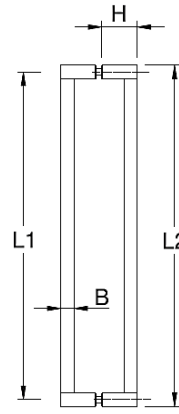

Size in mm

A	B	L1 (C/C)	L2	H	Finish
25	25	600	625	66.5	SSS
		1000	1025	66.5	SSS

Glass Preparation  $\varnothing$  12 - 15

PH-10

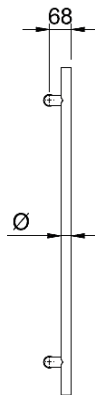
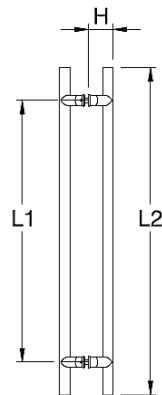

Size in mm

$\varnothing$	L1 (C/C)	L2	H	Finish
32	800	1000	76.5	SSS

Glass Preparation  $\varnothing$  12 - 15

PH-11





# PH SERIES DOOR HANDLES

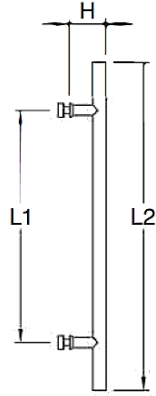

Size in mm

Ø	L1 (C/C)	L2	H
25	305	425	68
25	425	600	68

Glass Preparation Ø 12 - 15

**PH-13**  
Finish: PSS

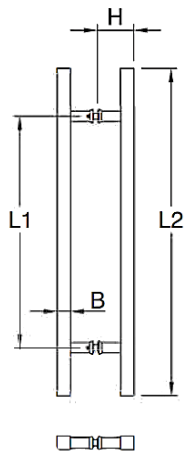

Size in mm

A	B	L1 (C/C)	L2	H
25	25	305	425	68
25	25	425	600	68

Glass Preparation Ø 12 - 15

**PH-14**  
Finish: SSS





# PH SERIES DOOR HANDLES

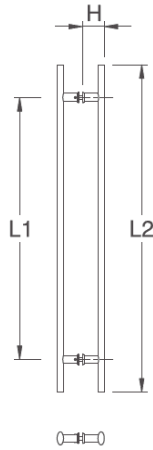

Size in mm

A	B	L1 (C/C)	L2	H
40	20	800	1000	68.5

Glass Preparation  $\varnothing$  12 - 15

**PH-15**  
Finish: SSS

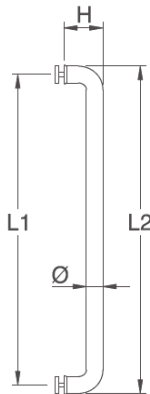

Size in mm

$\varnothing$	L1 (C/C)	L2	H
38	700	738	90

Glass Preparation  $\varnothing$  12 - 15

**PH-16**  
Finish: SSS

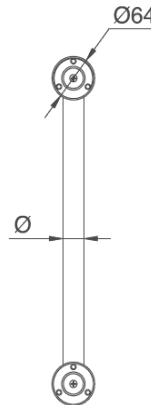
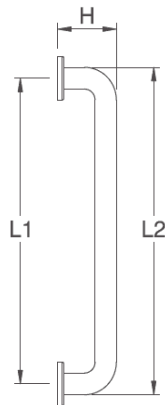

Size in mm

$\varnothing$	L1 (C/C)	L2	H
32	450	482	88
	750	782	88
	900	932	88

Wall Mount Handle

**PH-17**  
Finish: SSS



# PH SERIES DOOR HANDLES

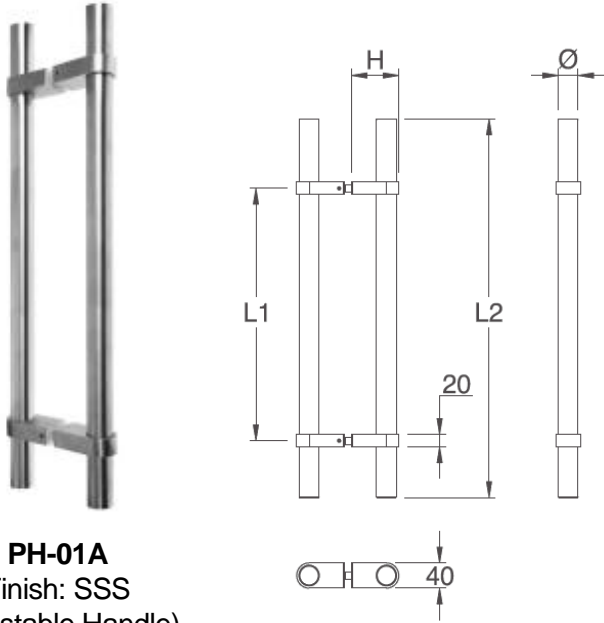

**PH-01A**  
Finish: SSS  
(Adjustable Handle)

Size in mm

Ø	L1 (C/C)	L2	H
32	80 - 580	600	77
	80 - 1160	1200	77

Glass Preparation Ø 12 - 15

## Glass Preparation for Pull Handle

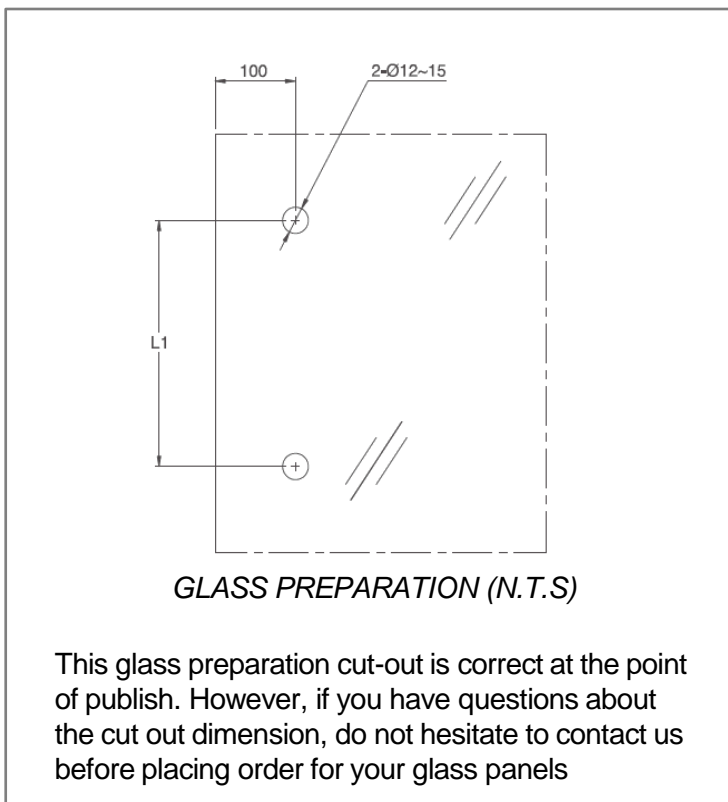

## Pull Handle End Cap





# PH SERIES DOOR HANDLES

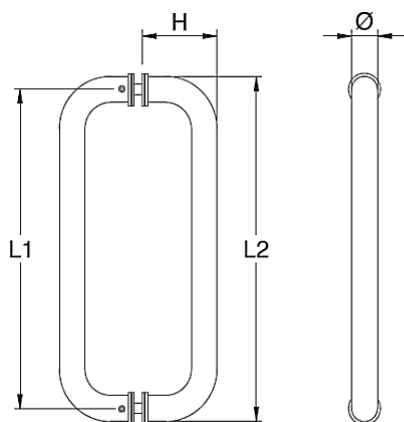

Size in mm

Ø	L1 (C/C)	L2	H
25	305	330	75
	425	450	75

Glass Preparation Ø 12 - 15

**PH-00-BK**  
Finish: BK

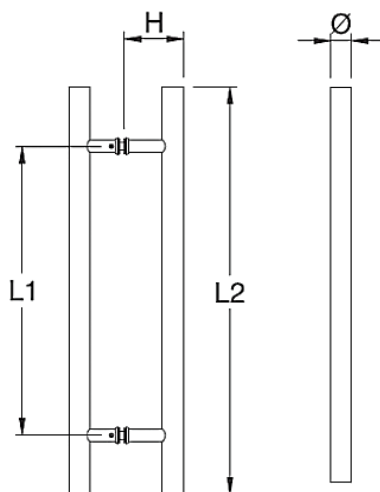

Size in mm

Ø	L1 (C/C)	L2	H
25	305	425	70
32	425	600	80
	1000	1200	80

Glass Preparation Ø 12 - 15

**PH-01-BK**  
Finish: BK

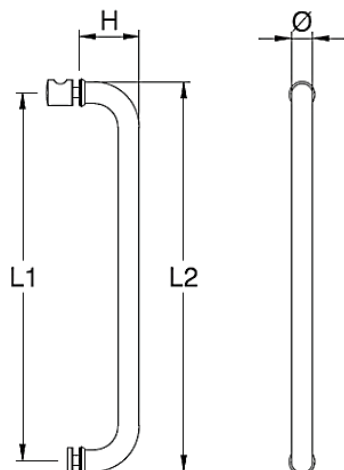

Size in mm

Ø	L1 (C/C)	L2	H
25	275	300	70
	305	330	70
	425	450	70

Glass Preparation Ø 12 - 15

**PH-05-N-800-BK**  
Finish: BK



# PH SERIES DOOR HANDLES

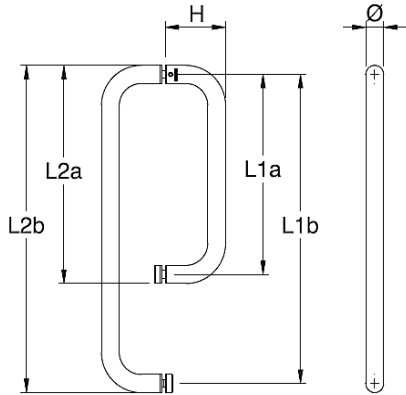

Size in mm

Ø	L1a (C/C)	L1b (C/C)	L2a	L2b	H
25	275	425	300	450	70

Glass Preparation  $\varnothing$  12 - 15

**PH-06-BK**  
Finish: BK

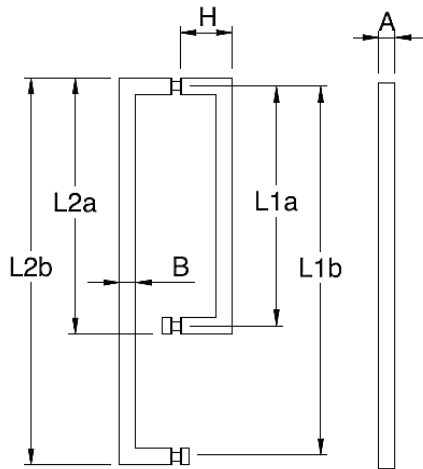

Size in mm

A	B	L1a (C/C)	L1b (C/C)	L2a	L2b	H
19	19	275	425	295	445	65

Glass Preparation  $\varnothing$  12 - 15

**PH-06S-BK**  
Finish: BK

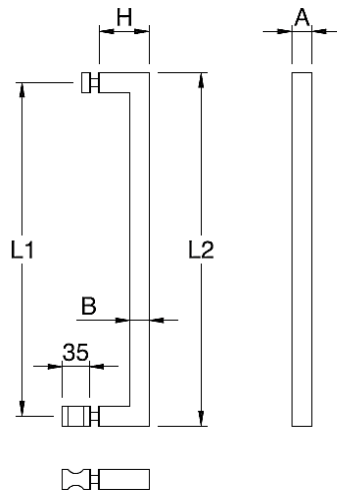

Size in mm

A	B	L1 (C/C)	L2	H
19	19	425	444	60

Glass Preparation  $\varnothing$  12

**PH-05S-BK**  
Finish: BK



# PH SERIES DOOR HANDLES

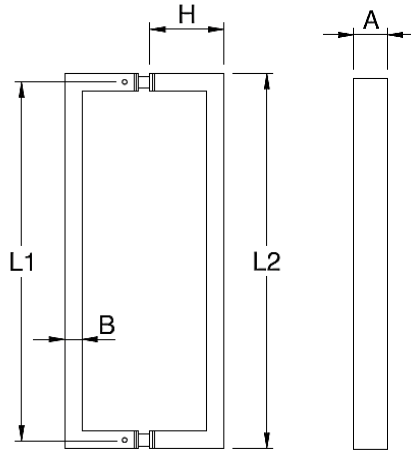

Size in mm

A	B	L1 (C/C)	L2	H
40	20	1000	1020	70

Glass Preparation  $\varnothing$  12

**PH-00R-BK**  
Finish: BK

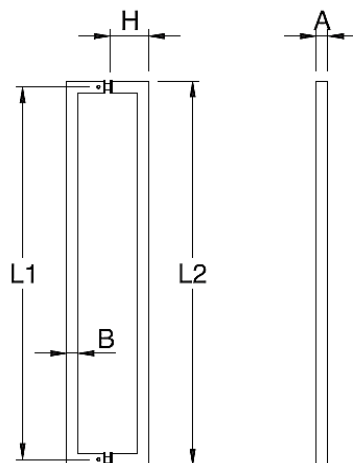

Size in mm

A	B	L1 (C/C)	L2	H
25	25	600	625	65
		1200	1225	65

Glass Preparation  $\varnothing$  12 - 15

**PH-00S-BK**  
Finish: BK



**Estron Marketing Pte. Ltd.**

141 Woodlands Industrial Park E5 E-terrace Singapore 757507

tel. +65 6853 9041 fax. +65 6853 9042

e-mail. sales@estron.com.sg url. www.estron.com.sg



*Product improvement is a continuous process,  
please check specifications at point of purchase.*