



ESTRONTM

ESTRON MARKETING PTE. LTD.



MS-100 Frameless Sliding System

Quality Architectural
Hardware Specialist

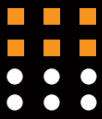

MS-100 FRAMELESS SLIDING SYSTEM

FEATURES

- Max weight per door leaf : 100kg
- Glass cut-out is required
- Glass Thickness: 8mm to 12mm
- Material: SUS304
- Finish: Satin (SSS)



MS-100-FB
Glass to Glass Fitting



MS-100-GC
Clamp Roller



MS-100-OP/1



MS-100-OP/2

Overhead Fitting

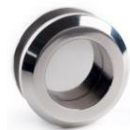

SDH-050-SS
Flush Handle



MS-100-CB
Glass to Wall Fitting



MS-100-FG
Floor Guide



MS-100-ST
Stopper



MS-100-WB
Wall Bracket

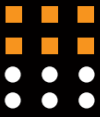

MS-100 FRAMELESS SLIDING SYSTEM

ELEVATION DRAWING:

Type 2: MS-100 Glass to Glass System

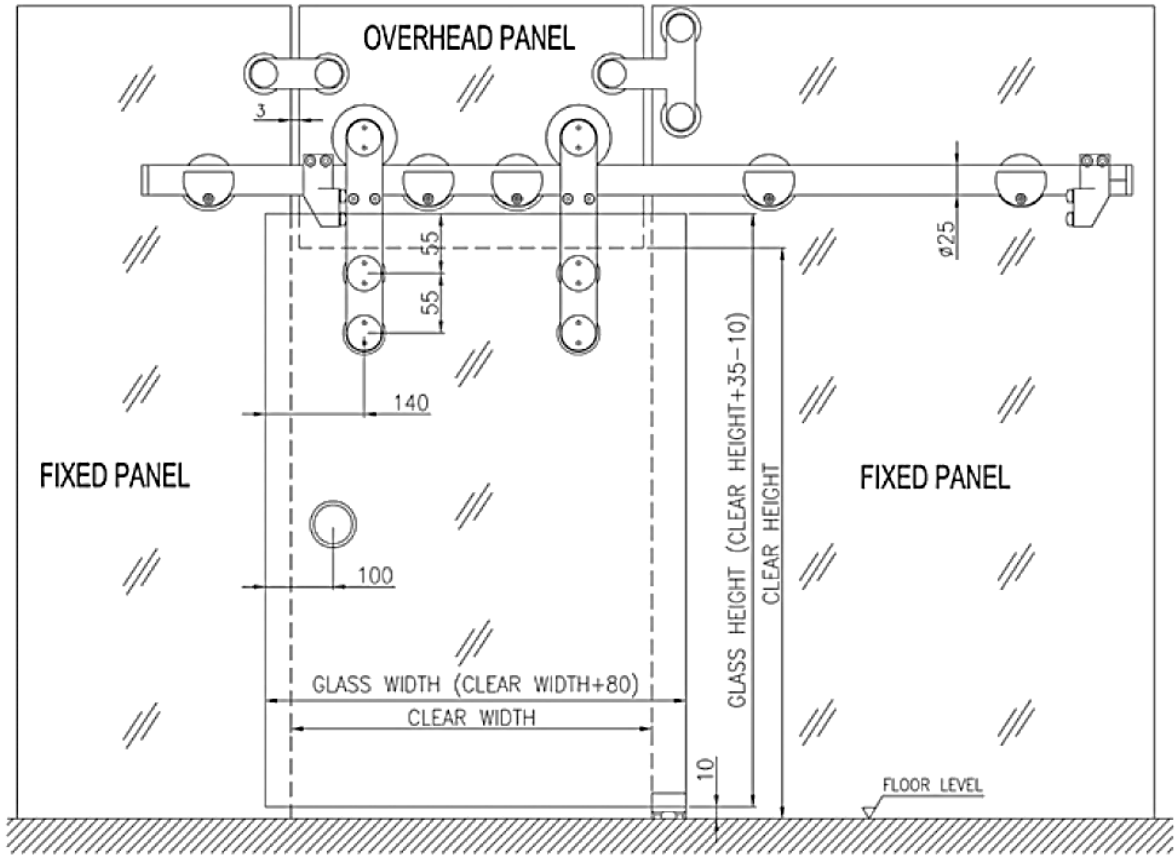

GLASS PREPARATION:

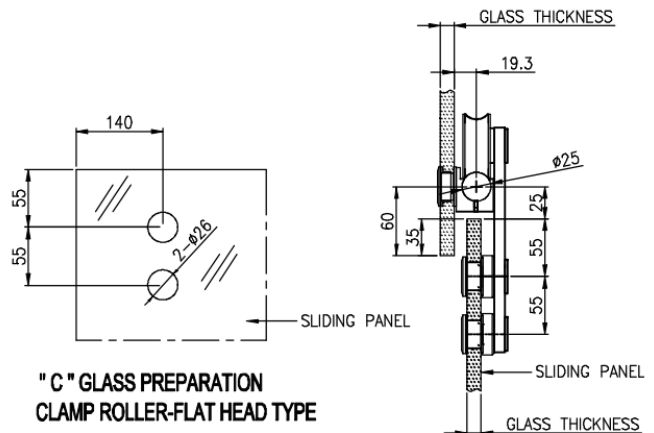
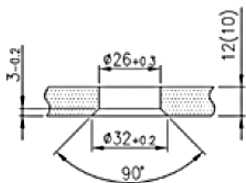
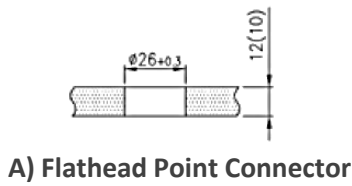

C) Clamp Roller (Glass to Glass)



Estron Marketing Pte. Ltd.

141 Woodlands Industrial Park E5 E-terrace Singapore 757507

tel. +65 6853 9041 fax. +65 6853 9042

e-mail. sales@estron.com.sg url. www.estron.com.sg



*Product improvement is a continuous process,
please check specifications at point of purchase.*