

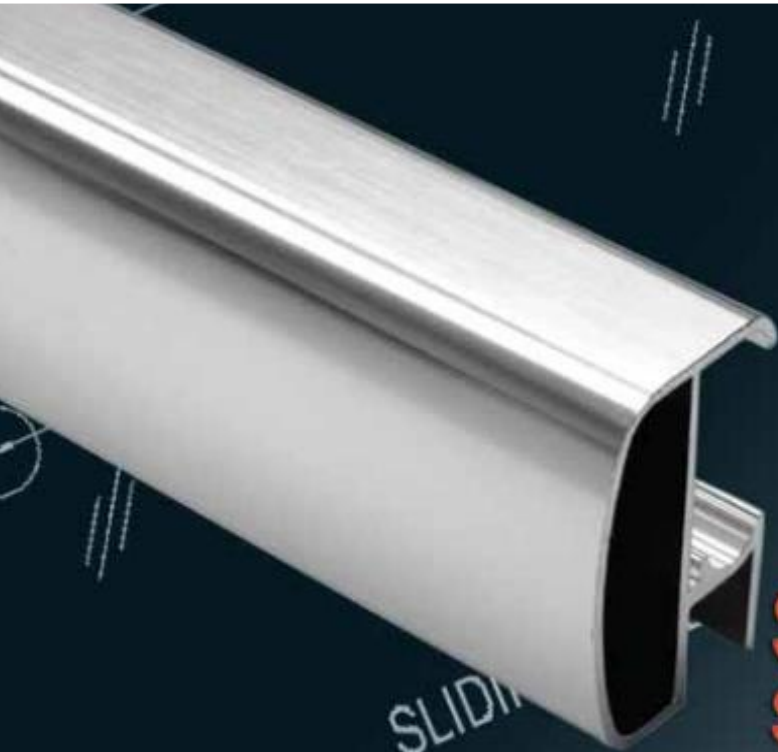

ESTRONTM

ESTRON MARKETING PTE. LTD.



SS-040
Sliding Shower
Screen

Quality Architectural
Hardware Specialist



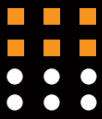

SS-040 SLIDING SHOWER SCREEN

FEATURES

- Max weight per door leaf : 50kg
- Glass cut-out is required
- Glass Thickness: 8mm to 12mm
- Finish: Polish (PSS) / Black (BK)



STRAIGHT ENTRY



SS-040-CR Clamp Roller

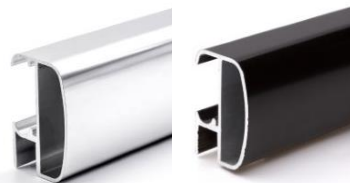

SS-040-RT Top Track



SS-040-ST Nylon Stopper w/ Catch Device



Nylon Floor Guide



SS-040 SLIDING SHOWER SCREEN

FEATURES

- Max weight per door leaf : 35kg
- Glass cut-out is required
- Glass Thickness: 8mm to 12mm
- Finish: Polish (PSS) / Black (BK)

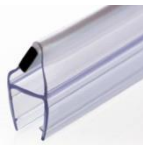

LSS-10CM Magnetic Sealing Strip



SS-040-B (L/R) Stainless Steel Mounting Bracket



JB-040 Track Elbow



OR



NOB-861 Door Knob

SDH-045-P Flush Handle



SS-040 SLIDING SHOWER SCREEN

Straight Entry

ELEVATION DRAWING:

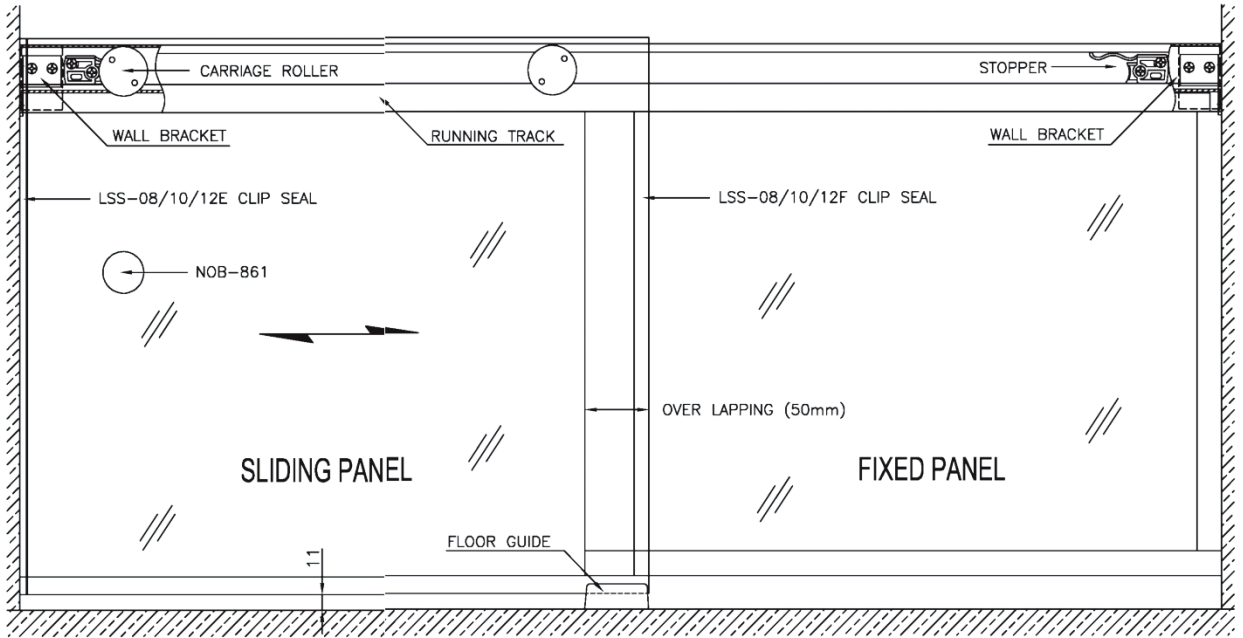

GLASS PREPARATION:

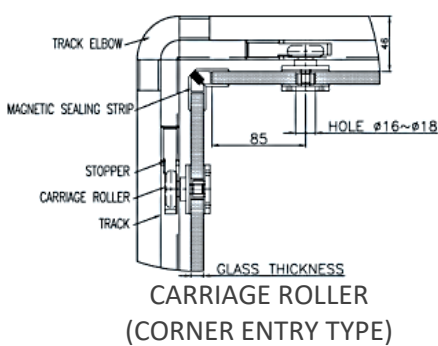

CARRIAGE ROLLER
(CORNER ENTRY TYPE)

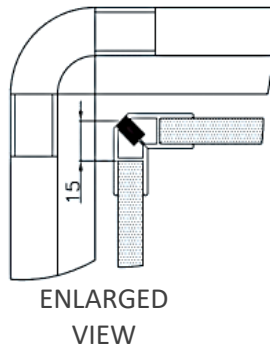

ENLARGED
VIEW

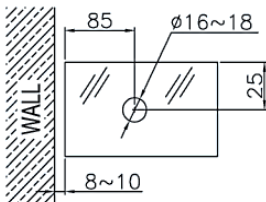

CARRIAGE ROLLER
(STRAIGHT TYPE)

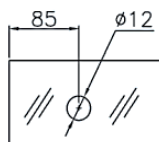

NOB-861
DOOR KNOB

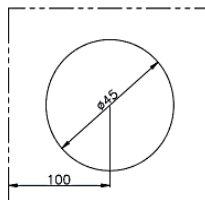

SDH-045-P
FLUSH HANDLE

SECTIONAL DRAWING:

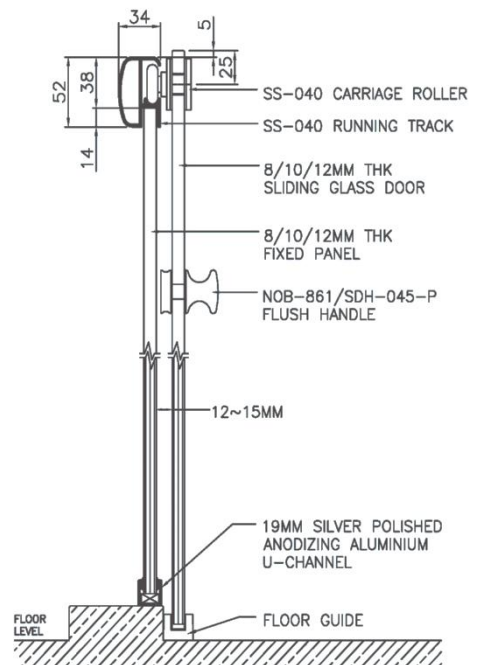



Estron Marketing Pte. Ltd.

141 Woodlands Industrial Park E5 E-terrace Singapore 757507

tel. +65 6853 9041 fax. +65 6853 9042

e-mail. sales@estron.com.sg url. www.estron.com.sg



*Product improvement is a continuous process,
please check specifications at point of purchase.*