



**ESTRON**<sup>TM</sup>

ESTRON MARKETING PTE. LTD.



**SC80** SOFT & SELF CLOSING SLIDING SYSTEM



## SLIM & COMPACT AESTHETICALLY PLEASING SOFT & SELF CLOSING FUNCTION

**ESTRON SC80 Soft & Self Closing Sliding System** provides an aesthetically pleasing system that is convenient as well. Consumers now have a much more economical choice for their residential entrance needs.

The soft closing function has a gentle and easy action, giving it a quiet and smooth glide.

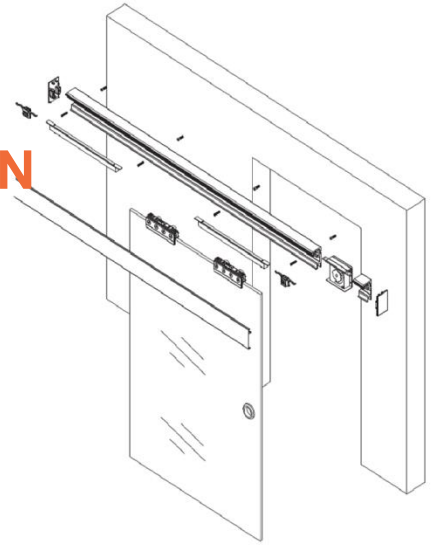

SC80-3 Illustration

## FEATURES

- Slim & Compact / Soft Closing / Soft & Self Closing
- Weight per door leaf: 100 – 120kg
- Glass Thickness: 10mm – 13.52mm
- Self-Closing SC80-3, max door width: 1200mm
- Easy opening and self-closing
- Left side or right side closing option

## CONFIGURATION

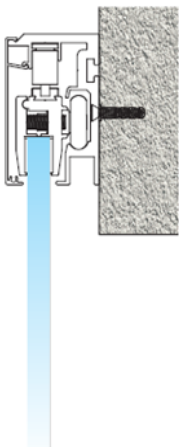

Wall Mounted  
Glass Panel Overlap

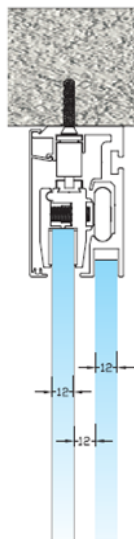

Ceiling Mounted

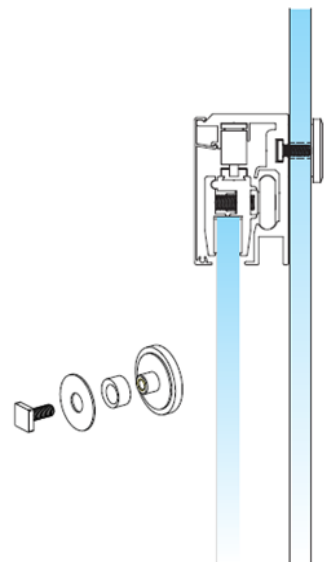

Fixed



## TYPE 1 – SLIM & COMPACT

### SC80-1 Set comprises of components list item: 1 – 7

Slim and Compact system is a Manual Sliding system as it's name suggest, the protruding part of system mechanism is minimal and aesthetically pleasing, giving home owners the pleasure of a sleek and minimalistic look, especially for residential bedrooms.

## TYPE 2 – SOFT CLOSING

### SC80-2 Set comprises of components list item: 1 – 8



On top of the base mechanism; Slim & Compact, the Soft Closing system has an addition of a damper added on to facilitate the process of halting before close. This function is perfect for families with children.

## TYPE 3 – SOFT & SELF CLOSING

### SC80-3 Set comprises of components list item: 1 – 9

Our Soft & Self-Closing Sliding system SC80 also comes with a self closing function. With the help of a Spring Gear, the Soft & Self-Closing system allows automatic closure after releasing the door.

## COMPONENT LIST

 <p>1. Glass Clamp Roller (SC80-GC) x 2 nos.</p>	 <p>2. End Cap (SC80-EC) x 2 nos.</p>	 <p>3. Stopper (SC80-ST) x 2 nos.</p>
 <p>4. Top Track 2.5m/3.0m/5.8m (SC80-RT) x 1 pc</p>	 <p>5. Alum. Cover, 2.5m (SC80-AC) x 1 pc</p>	 <p>6. Flush Handle, Polish (SDH-045-P) x 1 pc</p>
 <p>7. Floor Guide (FG-08/10/12) x 1 pc</p>	 <p>8. Damper (SC80-DP) x 2 nos.</p>	 <p>9. Spring Gear Box (Choose Left or Right) x 1 no. (L)</p>

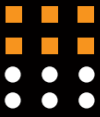

## FOR OVERHEAD & FIXED PANEL CONFIGURATION

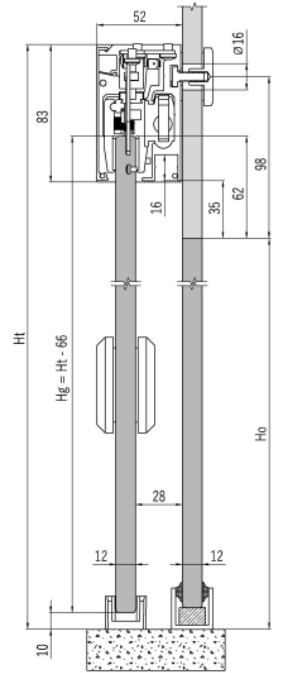
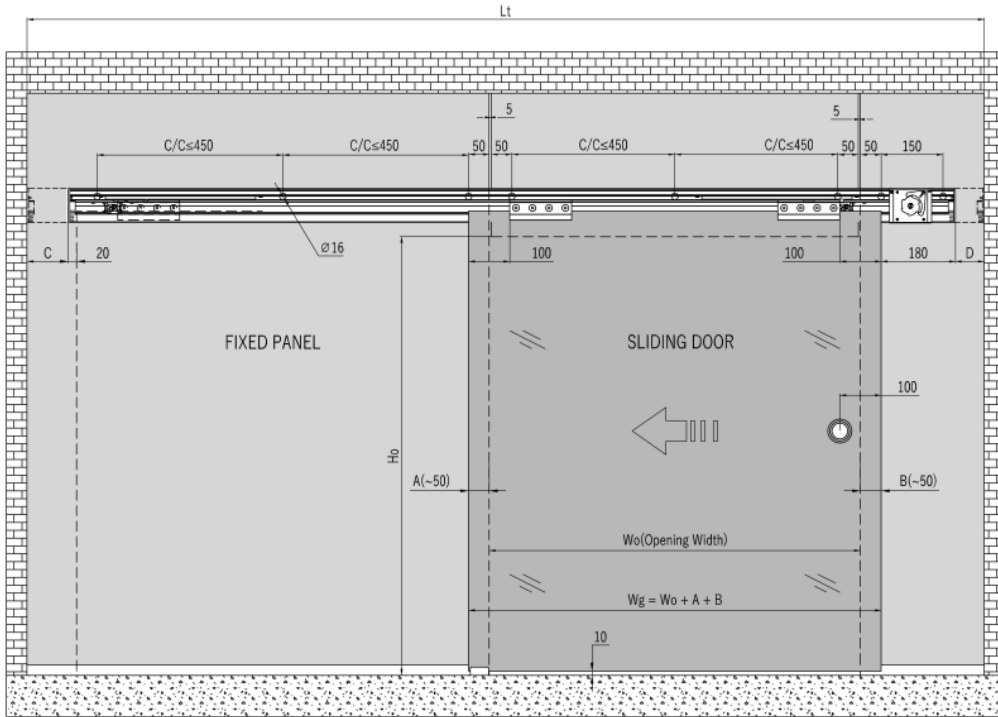

Sectional Drawing

## GLASS PREPARATION GUIDELINES FOR GLASS CLAMP

### Glass Preparation NOT REQUIRED for:

#### **Type 1 (SC80-1) & Type 2 (SC80-2)**

- Single Door leaf - All configurations
- Double Door leaf - All configurations

#### **Type 3 (SC80-3)**

- Single Door - Overlaps with min. 230mm (Both Wall or Glass)
- Single Door - With available space for top track beyond sliding door.

### Glass Preparation for glass clamp IS REQUIRED:

#### **Type 3 (SC80-3)**

- Single Door - Closes towards a wall / fixed glass at 90 degree.
- Double door leaf.

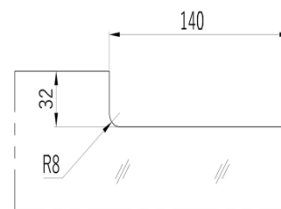

Glass Cut-Out



**Estron Marketing Pte. Ltd.**

141 Woodlands Industrial Park E5 E-terrace Singapore 757507

tel. +65 6853 9041 fax. +65 6853 9042

e-mail. sales@estron.com.sg url. www.estron.com.sg



*Product improvement is a continuous process,  
please check specifications at point of purchase.*