



ESTRONTM

ESTRON MARKETING PTE. LTD.



SF-80 SLIDING-FOLDING DOOR SYSTEM

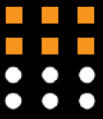

SF-80 SLIDING-FOLDING DOOR SYSTEM

MADE TO MEASURE OPTIONS, SAFE OPERATION, BETTER USER COMFORT

ESTRON Sliding-Folding Door SF-80 is slim and elegant, recommended for residential housings. Acting as a noise-free foldable partition, SF-80 offers you the flexibility to create your desired living space. It is safe, secure and simple to install, making it convenient for you to own an aesthetic door of your choosing.



ESTRON Sliding-Folding door SF-80 runs smoothly on an overhead track with noise-free suspension carriage. It is designed for up to 3.0m heights.

Without the use of a bottom track, dust will not accumulate, making it easy to maintain SF-80.

The accordion-style glass door allows natural light to enter and offers unhindered view. SF-80 acts as a noise-free foldable partition and with quick handling, you can achieve your desired living space.



Slim and elegant, SF-80 creates spacious living areas and saves space when folded. It is highly recommended for residential housings. Safe, secure and simple to install, it is convenient for you to own an aesthetic door of your choosing.

SF-80 is available exclusively in matte black, which has a modern appeal. Unlike polished steel, matte black is fingerprint-resistant. SF-80 is aesthetically pleasing and effortlessly portrays a slim and elegant appearance, suitable for Singapore's residential living spaces.



TYPICAL INSTALLATION

ESTRON Sliding-Folding door systems are made up of the following components:

Top Track for direct mounting to a steel girder or similar on the ceiling.

Top and bottom rails composed of base rail, clip on covers and end caps, which are clamped onto the toughened glass panels

Higher Quality rollers, carriers, and carrier profiles ensures that the panels could slide easily with minimal effort.

DOOR DIMENSION

Max. Panel Height: Up to 3000mm

Max. Panel Width: Up to 750mm

Optimal Panel size for easy sliding

approx.: 700mm x 2500mm

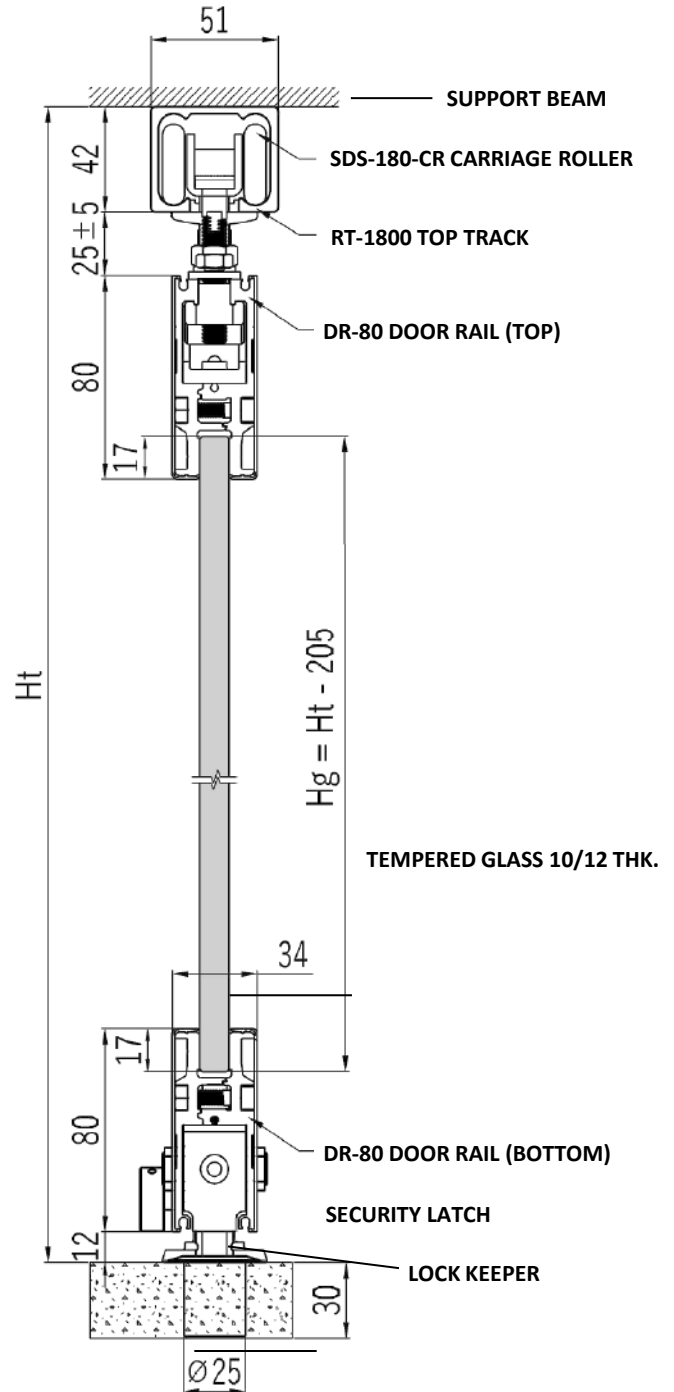

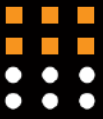

STACKING LAYOUT

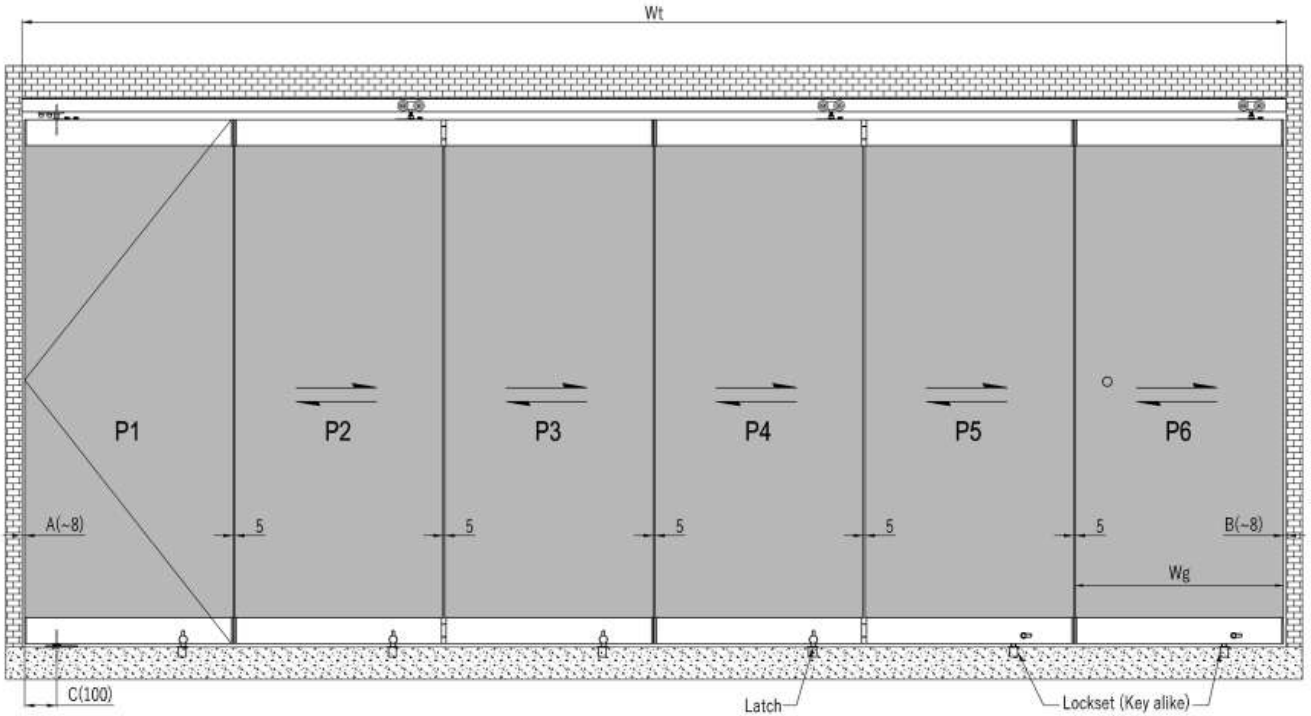

Most popular stacking layout:

1. For systems with 2, 4, or 6 panels, it is recommended to open the system from inside only.
2. For a 3 Panel System, the first 2 panels will be latched and the 3rd panel will be used as a swing door.
3. For a 5 panel system, the first 4 panels will be latched and the 5th panel will be used as a swing door.

TYPICAL PARKING CONFIGURATION

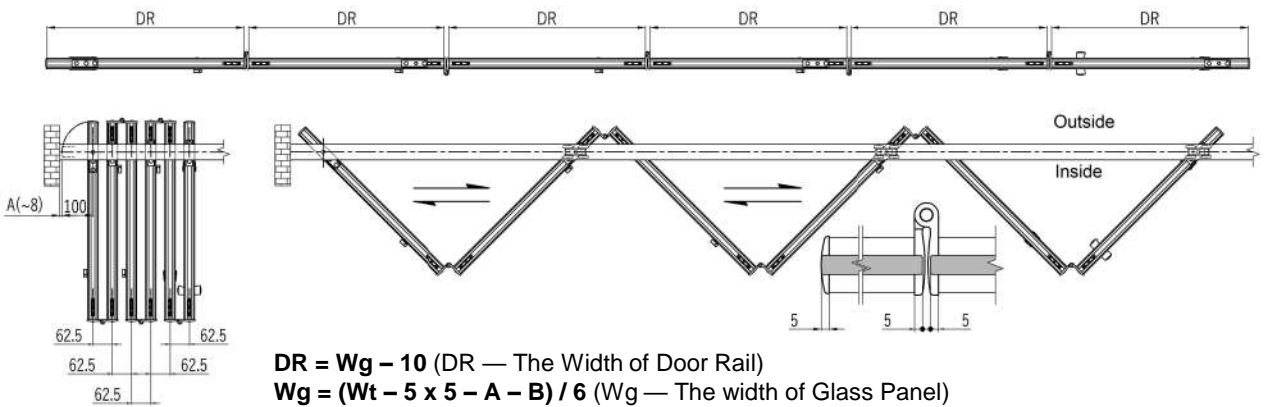

$DR = Wg - 10$ (DR — The Width of Door Rail)

$Wg = (Wt - 5 \times 5 - A - B) / 6$ (Wg — The width of Glass Panel)

Applied for Glass Thickness: 10, 12mm



SF-80 SLIDING-FOLDING DOOR SYSTEM

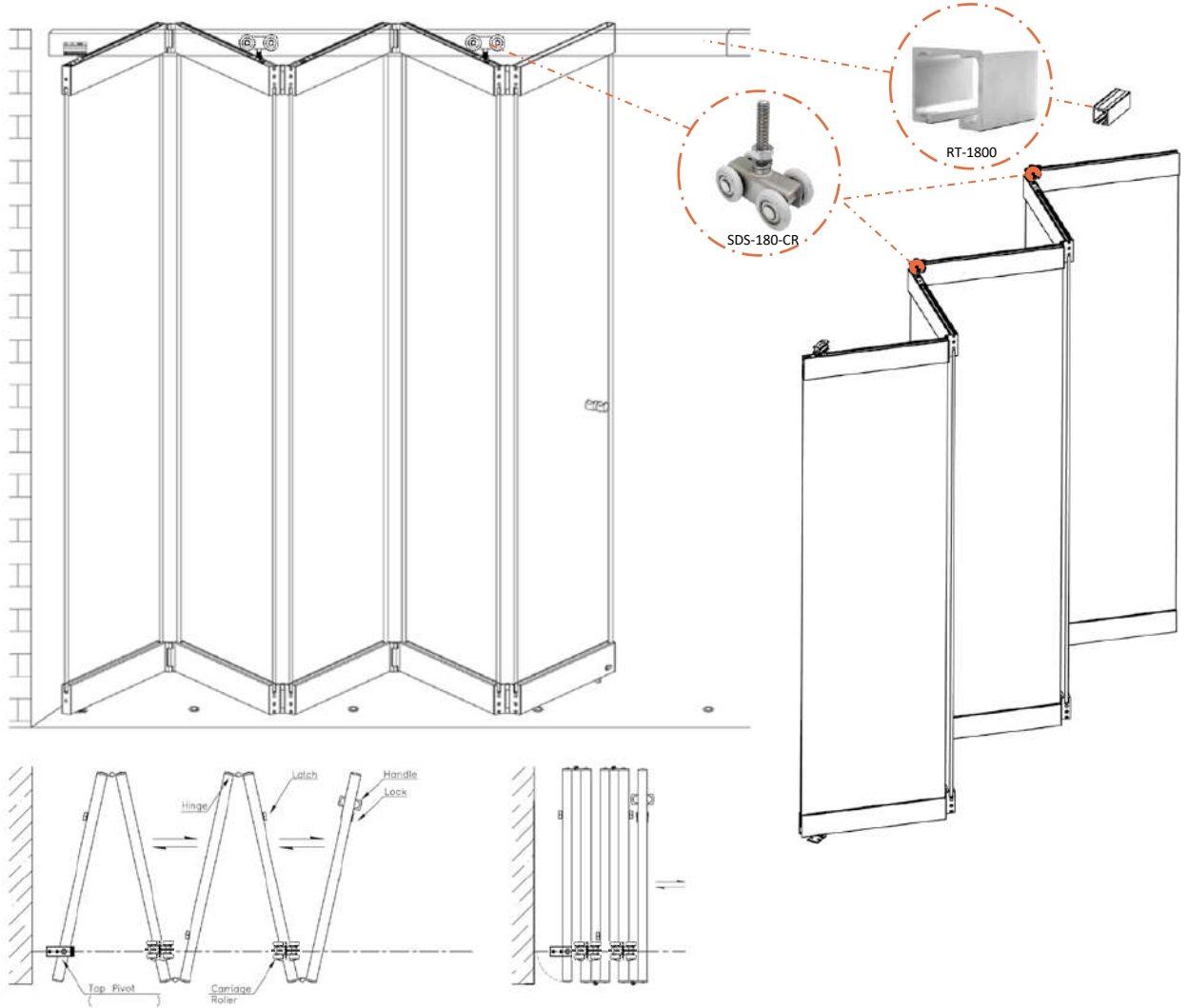

CROSS SECTION

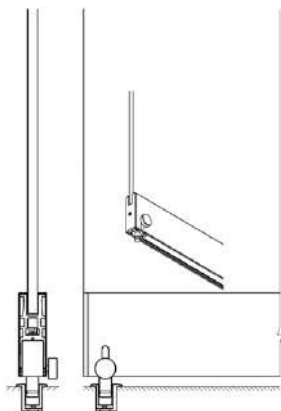

Bottom Rail c/w Latch

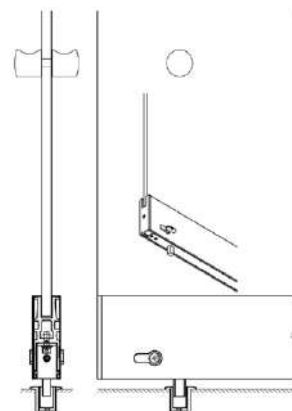

Bottom Rail c/w Lockset



ACCESSORIES

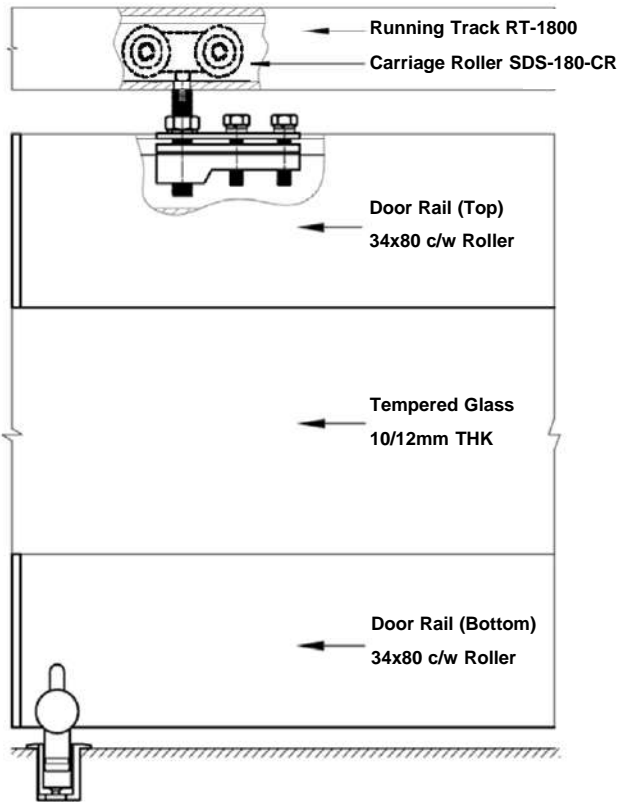

Top Rail c/w Carriage Roller

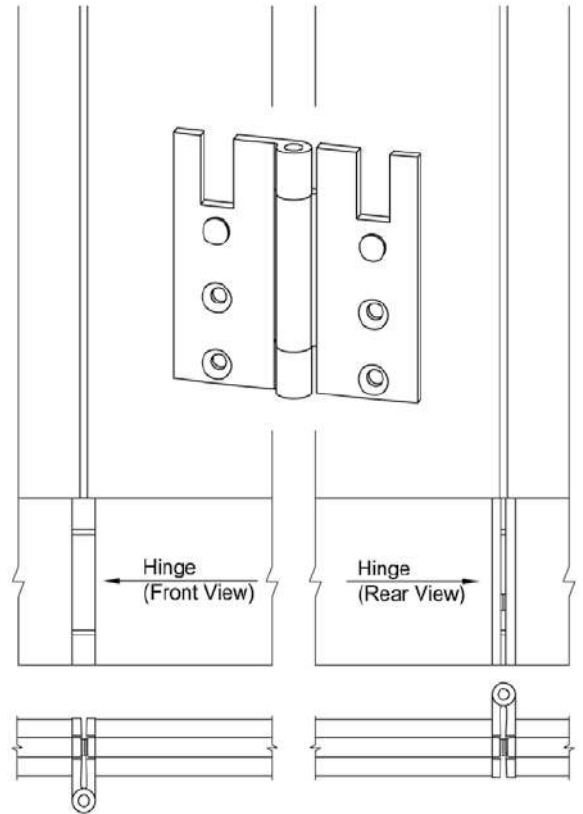

Door Rail c/w Hinge

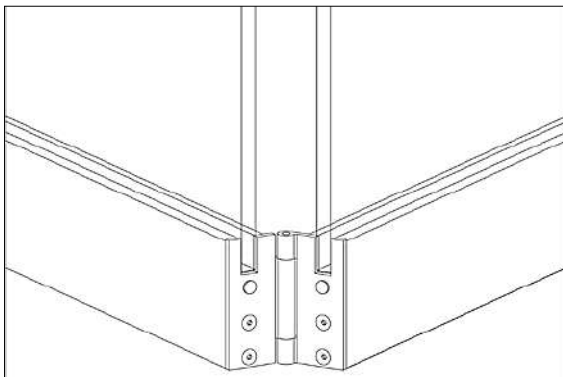

Bottom Rail c/w Hinge

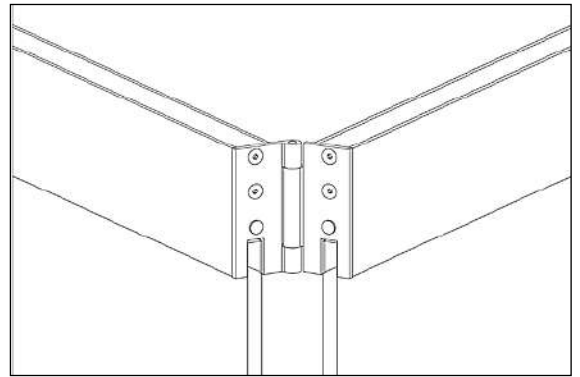

Top Rail c/w Hinge



SF-80 SLIDING-FOLDING DOOR SYSTEM

ACCESSORIES



SP-80
Stopper



SDS-540
Lockset Bolt



SDS-400T
Latch



SDS-360-S / SDS-360B
Bolt Keeper



TC-100.1-Set
Top Pivot



BP-100-Set
Floor Pivot



DR-080.EC.330
DR-080.EC.330-BK
End Cap



SF-80-Hinge
SF-80-Hinge-BK
Door Hinge



RT-1800 / RT-1800-BK
Running Track



SDS-180-CR
Carriage Roller Set

HANDLE & CLIP SEAL



SDH-050-S



NOB-800



NOB-860
NOB-860-BK



SDH-070



LSS-10A/12A
LSS-10A/12A-BK



LSS-10E/12E
LSS-10E/12E-BK



Estron Marketing Pte. Ltd.

141 Woodlands Industrial Park E5 E-terrace Singapore 757507

tel. +65 6853 9041 fax. +65 6853 9042

e-mail. sales@estron.com.sg url. www.estron.com.sg



*Product improvement is a continuous process,
please check specifications at point of purchase.*