



ESTRONTM

ESTRON MARKETING PTE. LTD.



SF-100 SLIDING-FOLDING DOOR SYSTEM



MADE TO MEASURE OPTIONS, SAFE OPERATION, BETTER USER COMFORT



ESTRON Sliding-Folding door (SF-100) consists of small elegant metal patch hinges and noise free suspension carriage, which runs smoothly in an overhead track.

It features an accordion-style glass door designed for quick handling. Designed for up to 3.0m height.

ESTRON Sliding-Folding system is safe and practical, easy and quick to open and close, simple to install, durable and effective.





TYPICAL INSTALLATION

ESTRON Sliding-Folding door systems are made up of the following components:

Top Track for direct mounting to a steel girder or similar on the ceiling.

Top and bottom rails composed of base rail, clip on covers and end caps, which are clamped onto the toughened glass panels

Rollers, carriers, and carrier profiles which ensure that the panels are sliding easily with minimum effort.

DOOR DIMENSION

Max. Panel Height: Up to 3000mm

Max. Panel Width: Up to 800mm

Optimal Panel size for easy sliding

approx. : 700mm x 2500mm

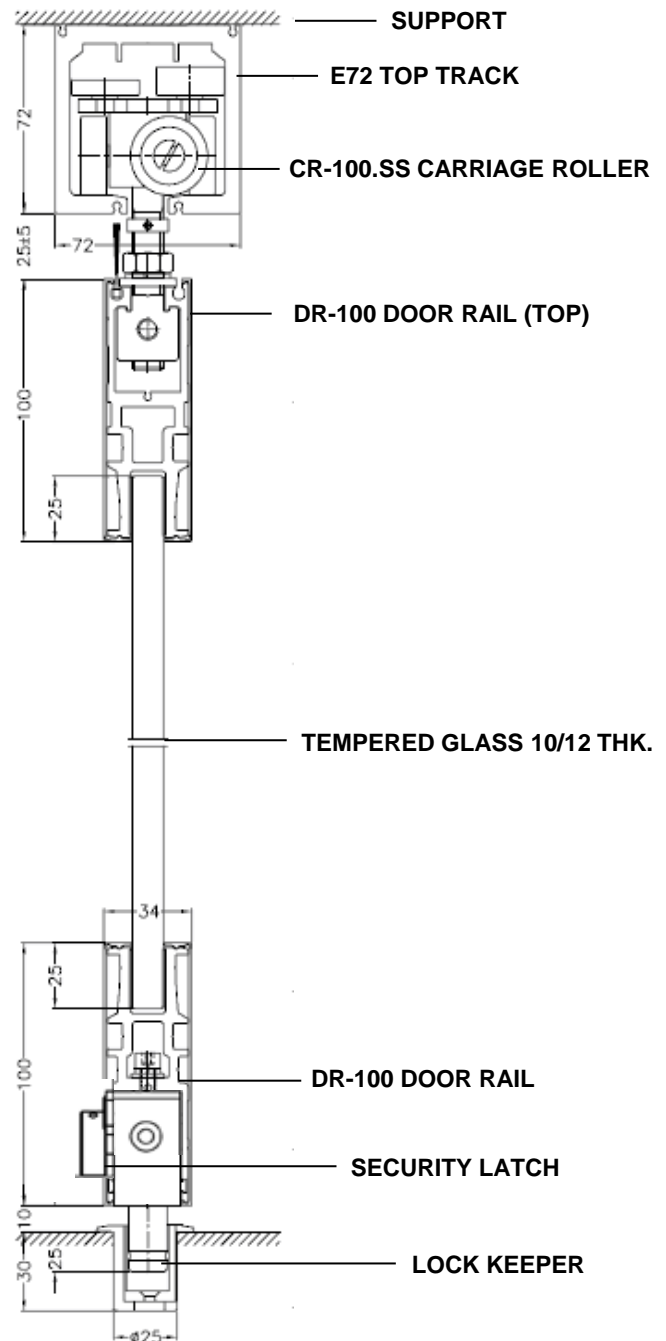



STACKING LAYOUT

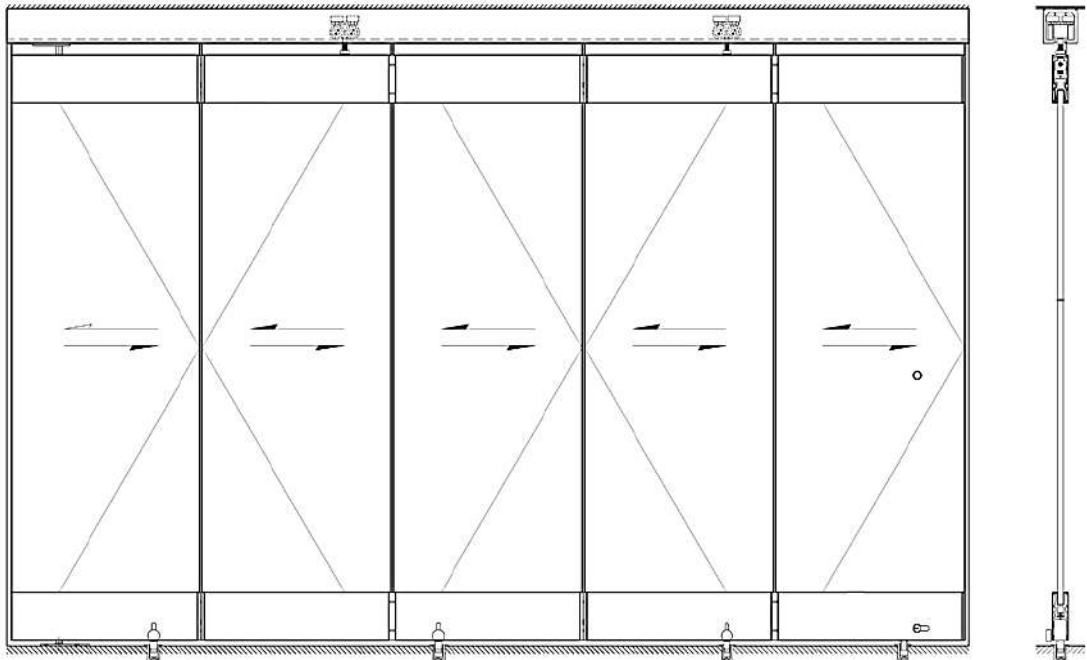

Most popular stacking layout:

1. For systems with 2, 4, or 6 panels, it is recommended to open the system from inside only.
2. For a 3 Panel System, the first 2 panels will be latched and the 3rd panel will be used as a swing door.
3. For a 5 panel system, the first 4 panels will be latched and the 5th panel will be used as a swing door.

TYPICAL PARKING CONFIGURATION

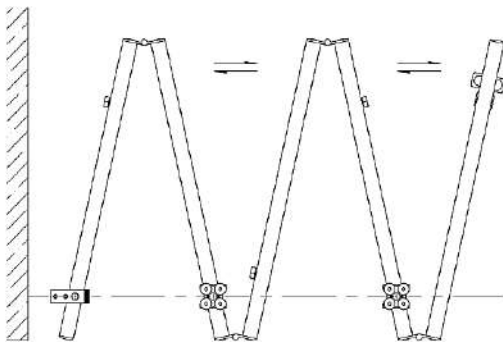

Layout 1

Parking Legend:

N = No. of Panels

$$Wc = (N-1) \times 65 + B(65) + A(5-10) + 17$$

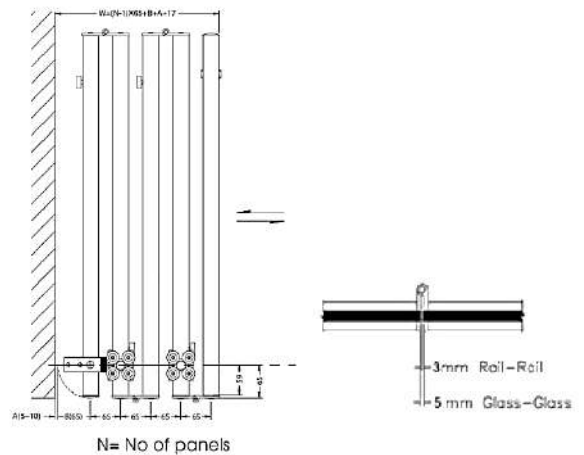



SF-100 SLIDING-FOLDING DOOR SYSTEM

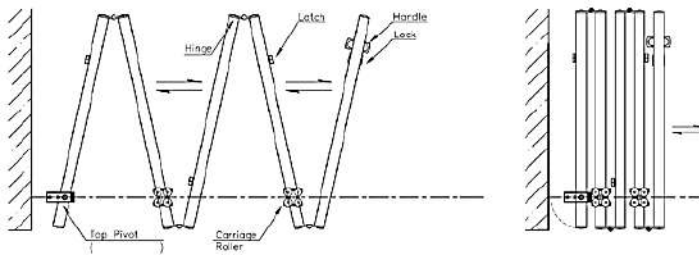
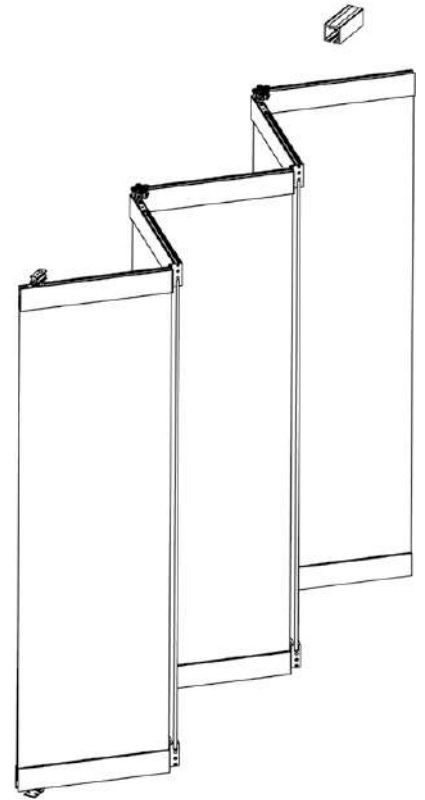
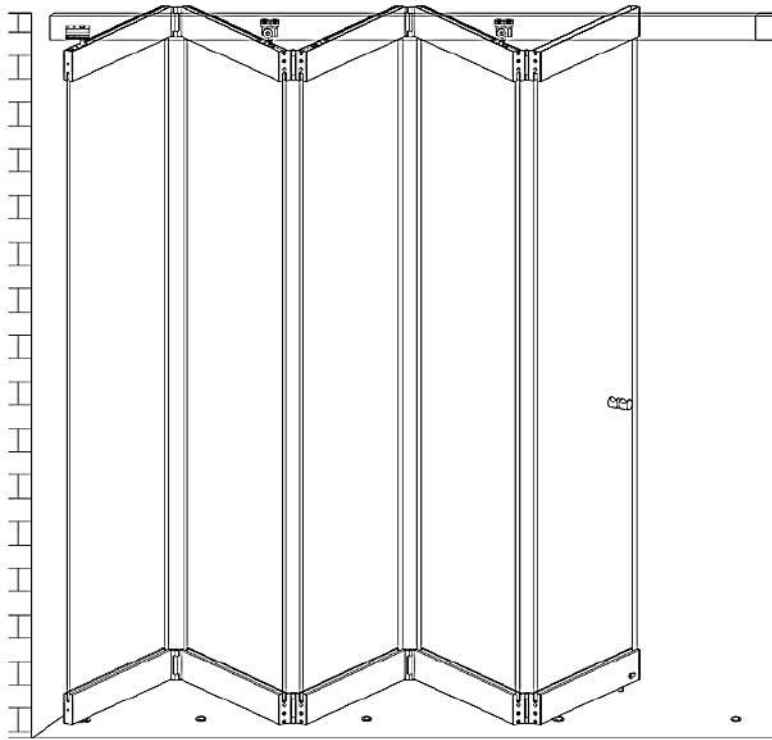

CROSS SECTION

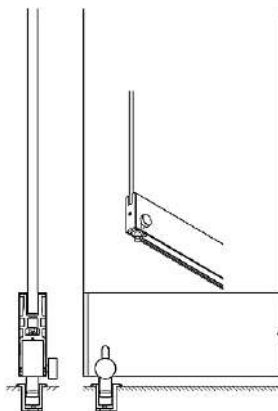

Bottom Rail c/w Latch

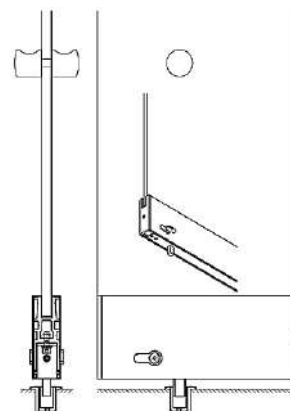

Bottom Rail c/w Lockset



ACCESSORIES

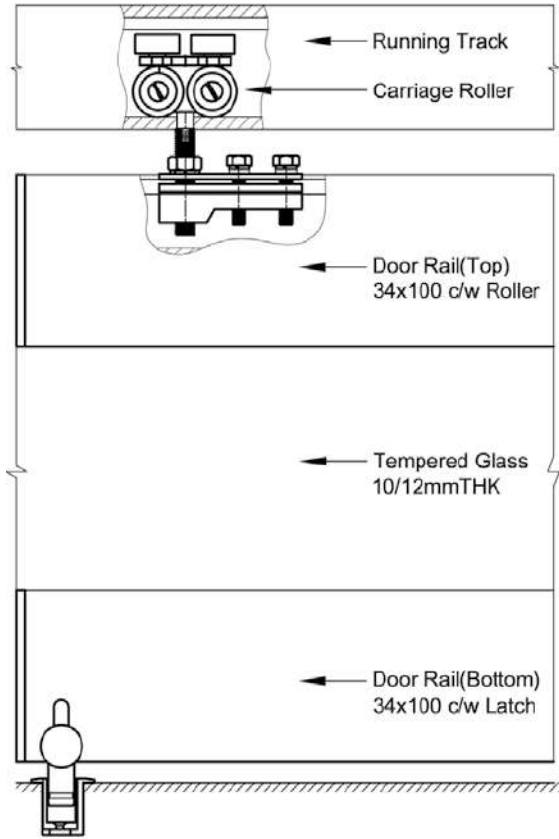

Top Rail c/w Carriage Roller

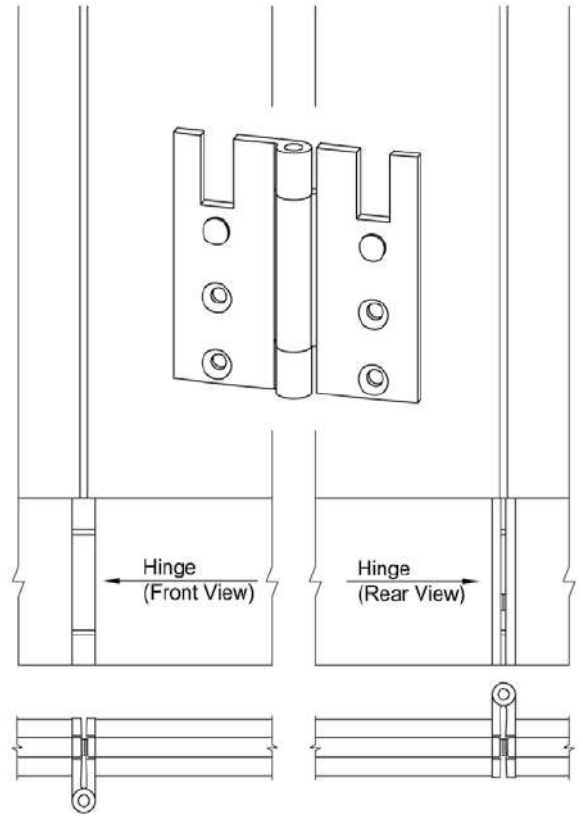

Door Rail c/w Hinge

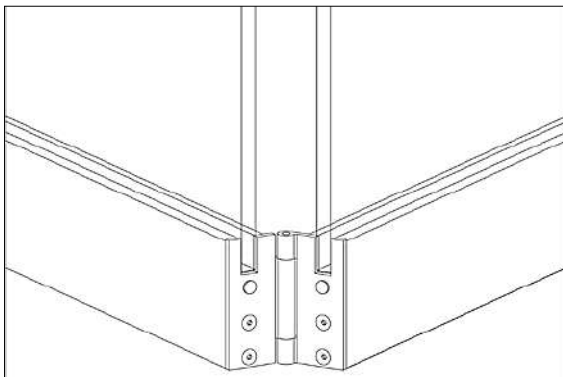

Bottom Rail c/w Hinge

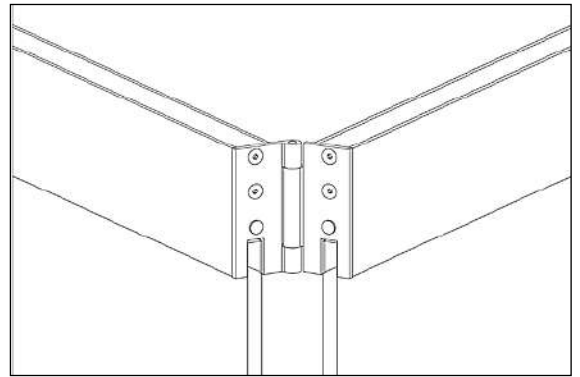

Top Rail c/w Hinge



ACCESSORIES



SP-100
Stopper



SDS-540
Lockset Bolt



SDS-400T
Latch



SDS-360-S / SDS-360B
Bolt Keeper



TC-100.1-Set
Top Pivot



BP-100-Set
Floor Pivot



SDS-340-S
End Cap



SF-100-Hinge



E72
Running
Track



CR-100.SS
Carriage Roller
Set

HANDLE & CLIP SEAL



SDH-050-S



NOB-800



NOB-860
NOB-860-BK



SDH-070



LSS-10A/12A
LSS-10A/12A-BK



LSS-10E/12E
LSS-10E/12E-BK



Estron Marketing Pte. Ltd.

141 Woodlands Industrial Park E5 E-terrace Singapore 757507

tel. +65 6853 9041 fax. +65 6853 9042

e-mail. sales@estron.com.sg url. www.estron.com.sg



*Product improvement is a continuous process,
please check specifications at point of purchase.*