



ESTRONTM

ESTRON MARKETING PTE. LTD.



SS-100 SLIDING-STACKING DOOR SYSTEM



MADE TO MEASURE OPTIONS, SAFE OPERATION, BETTER USER COMFORT

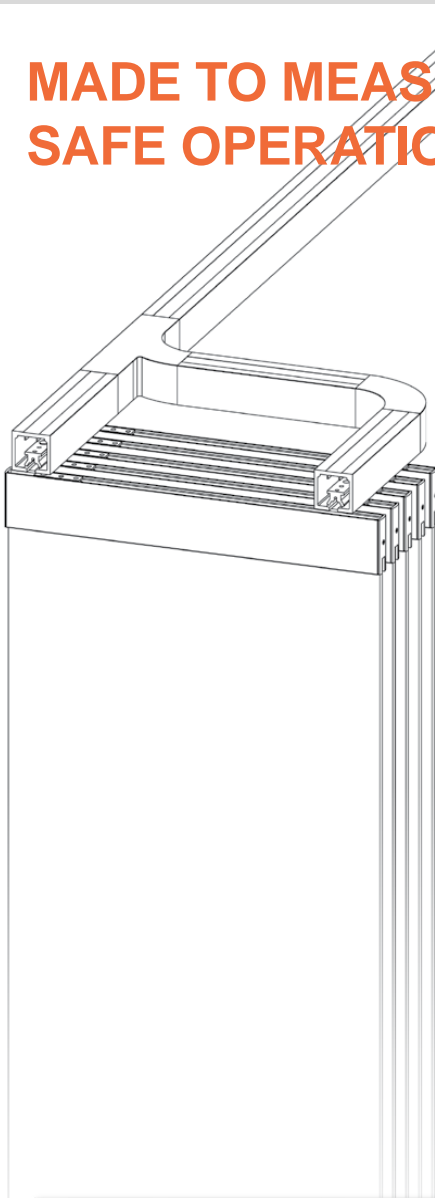

ESTRON Sliding-Stacking Door system is an aluminum track and hanger system which transports semi-frame glass panels and aluminum framed doors through 45, 90, 135 degree switches for closing off big opening areas by stacking the panels or doors.

The advantage of this system is that there is no need to use a floor guide or channel guide on the floor. The only visible parts are the top and bottom door rails, so that even when the system is closed, it presents a clean, attractive, transparent frontage.

Therefore the product is ideally suited for shop fronts, hotels, convention centers, corporate offices and private houses.

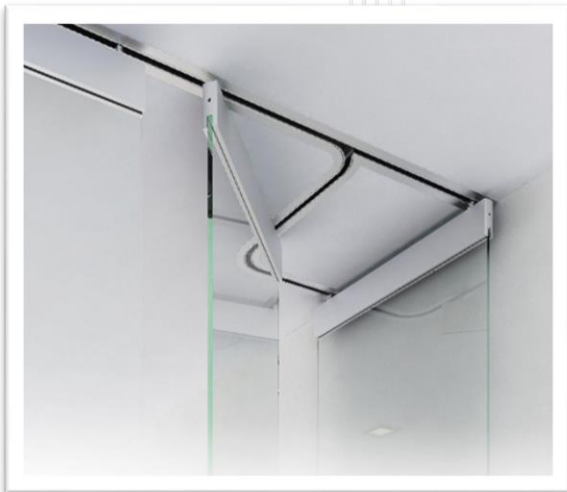



TYPICAL INSTALLATION

- **ESTRON Sliding-Stacking door systems** are made up of the following components:
- Top Track for direct mounting to a steel girder or similar on the ceiling.
- Top and bottom rails composed of base rail, clip on covers and end caps, which are clamped onto the toughened glass panels
- Rollers, carriers, and carrier profiles which ensure that the panels are sliding easily with minimum effort.
- Stacking areas, in which the sliding panels are neatly and compactly stacked when the door is opened

DOOR DIMENSION

Max. Panel Height: Up to 3600mm

Max. Panel Width: Up to 1100mm

Optimal Panel size for easy sliding

approx.: 800mm x 2500mm

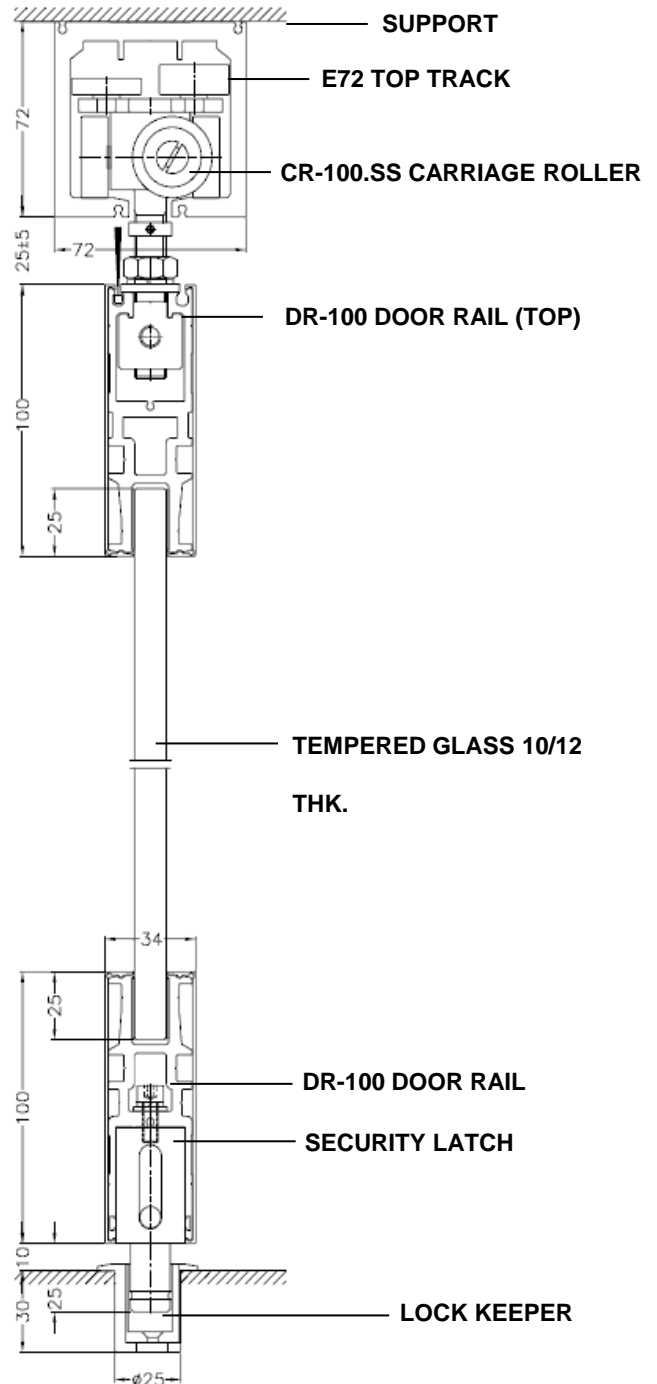

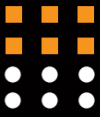

STACKING LAYOUT

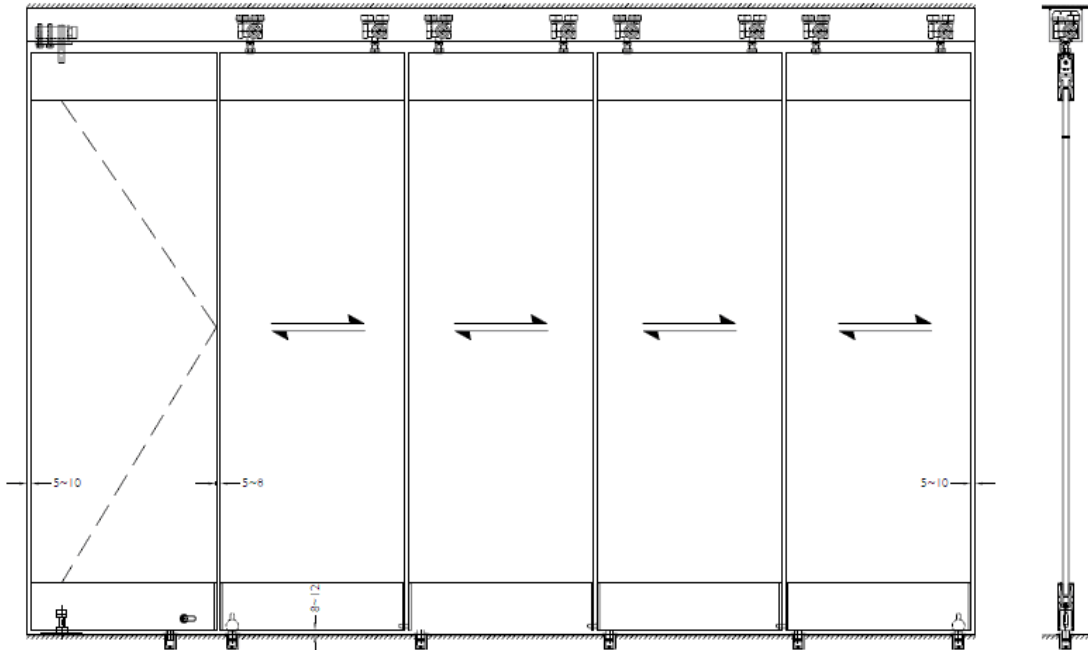

Most popular stacking layout, where the end panel might be a swing door:

1. Swing door (end panel)
2. Sliding panel
3. Stacking area (when the system is opened, sliding panels can be arranged to sliding to the left or to right)

TYPICAL PARKING CONFIGURATION

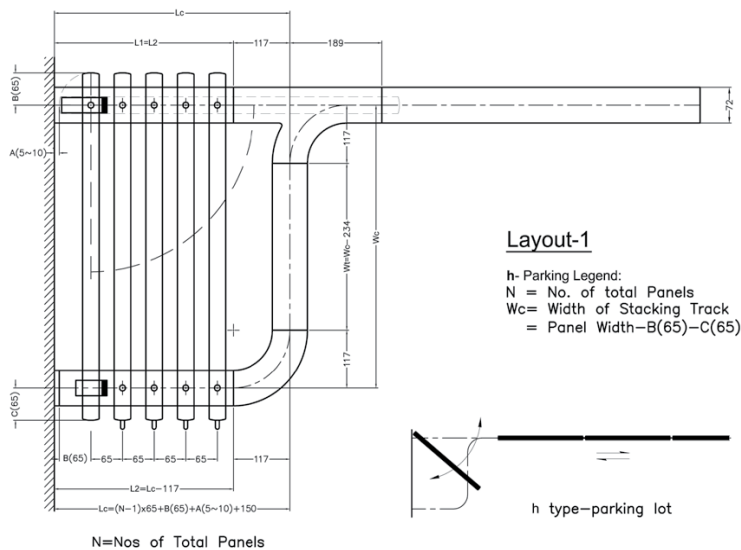



SS-100 SLIDING-STACKING DOOR SYSTEM

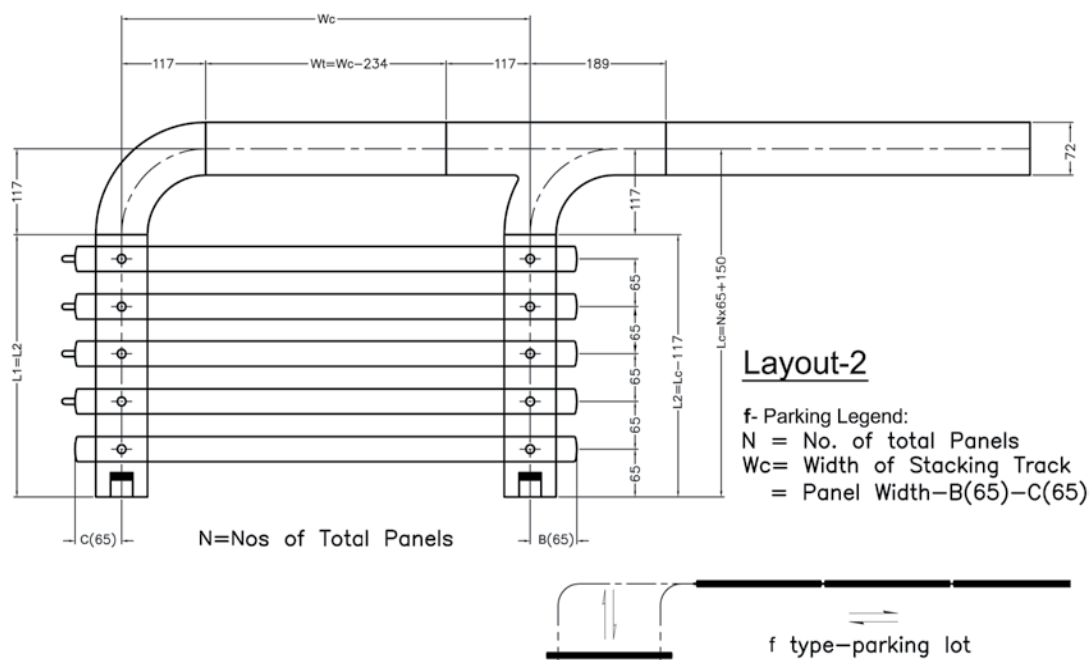

CROSS SECTION

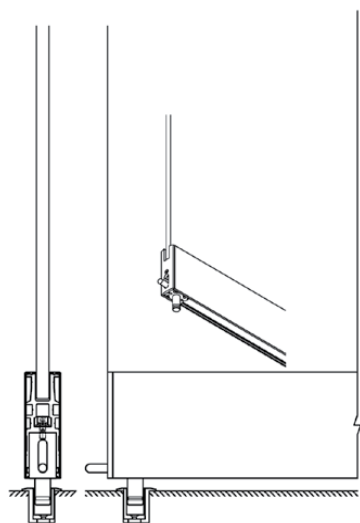

**Sliding Panel
c/w Security Latch**

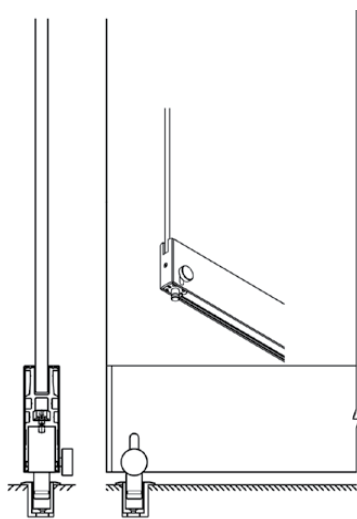

**Sliding Panel
c/w Thumb Push Latch**

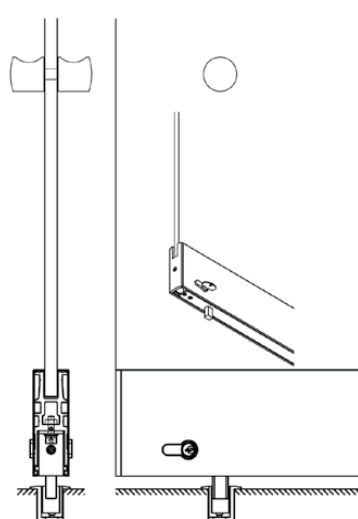

**Sliding/Swing Panel
c/w Lockset**



ALUMINIUM TOP TRACK

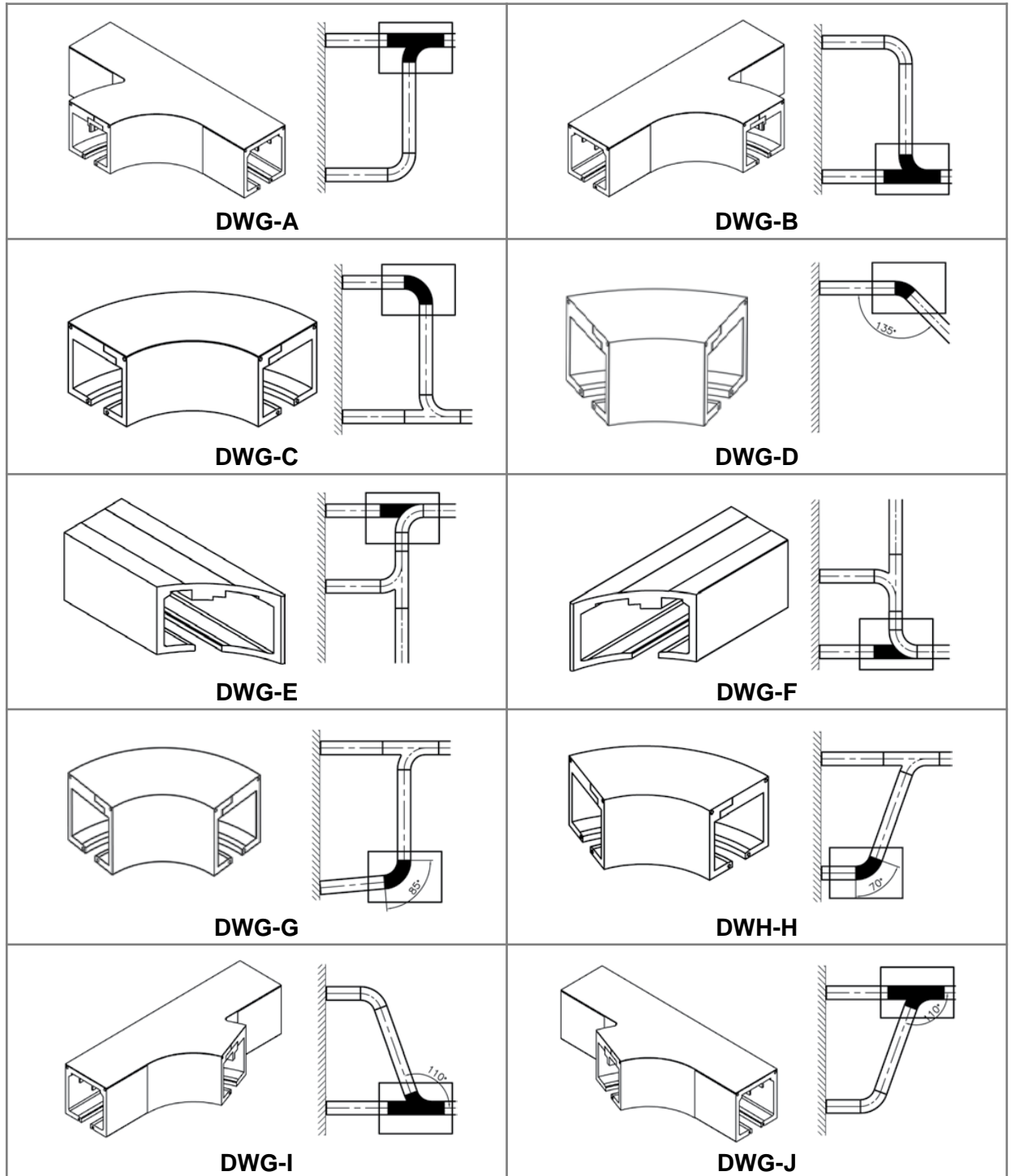



ACCESSORIES

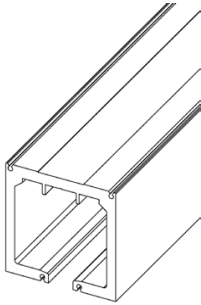

Running Track

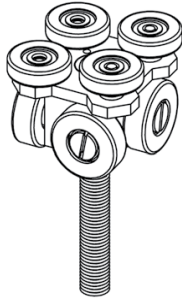

Carriage Roller

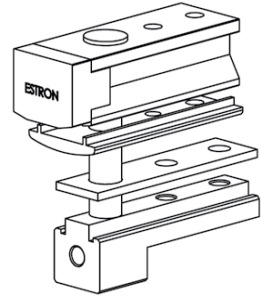

Top Pivot

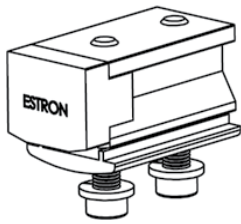

Stopper

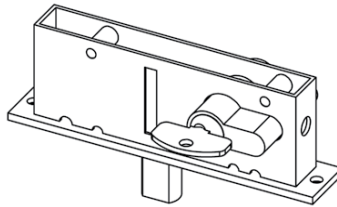

Lock Set

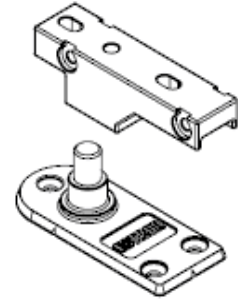

Floor Pivot

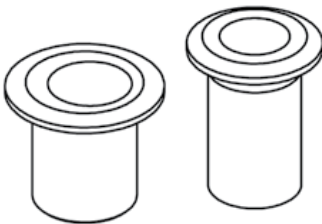

Bolt Keeper



End cap 1

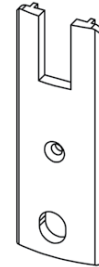

End Cap 2

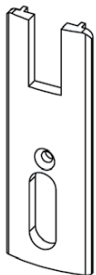

End Cap 3



Estron Marketing Pte. Ltd.

141 Woodlands Industrial Park E5 E-terrace Singapore 757507

tel. +65 6853 9041 fax. +65 6853 9042

e-mail. sales@estron.com.sg url. www.estron.com.sg



*Product improvement is a continuous process,
please check specifications at point of purchase.*