



ESTRONTM

ESTRON MARKETING PTE. LTD.



SLIDING DOOR GEAR

Quality Architectural
Hardware Specialist

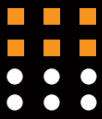

SDS-020 SLIDING DOOR GEAR

FEATURES

- For one or more door leaves with or without side panels
- Suitable for 6mm to 8mm thick tempered glass
- Gentle, easy action and glass cut-out is required
- Maximum weight per door leaf: 20kg

TECHNICAL DRAWINGS:

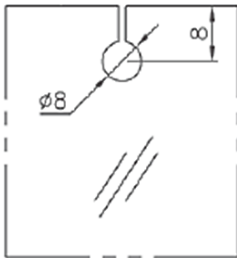
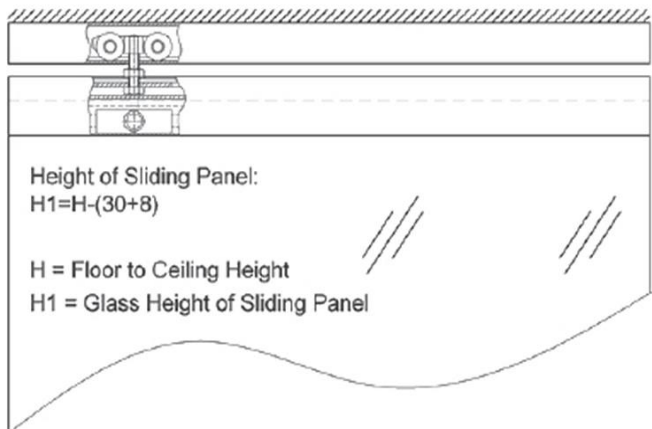

GLASS PREPARATION

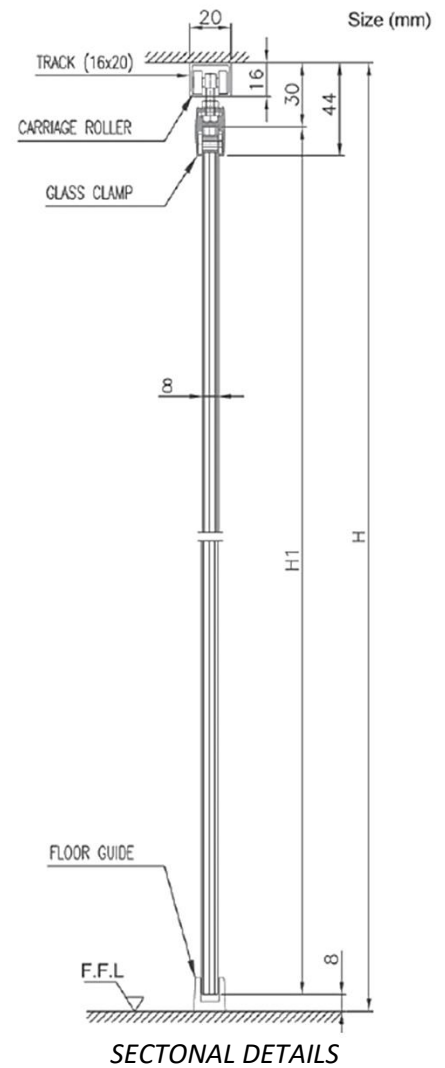

COMPLETE SET:





SDS-040 SLIDING DOOR GEAR

FEATURES

- For one or more door leaves with or without side panels
- Suitable for 8mm to 10mm thick tempered glass
- Gentle, easy action and glass cut-out is required
- Maximum weight per door leaf: 40kg

TECHNICAL DRAWINGS:

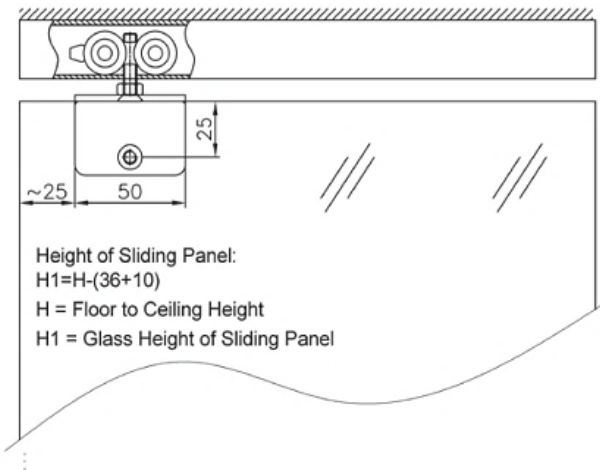

Height of Sliding Panel:
 $H1 = H - (36 + 10)$
 H = Floor to Ceiling Height
 $H1$ = Glass Height of Sliding Panel

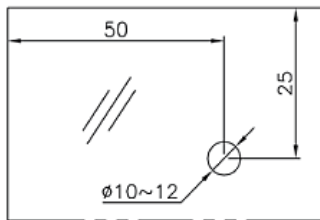

GLASS PREPARATION

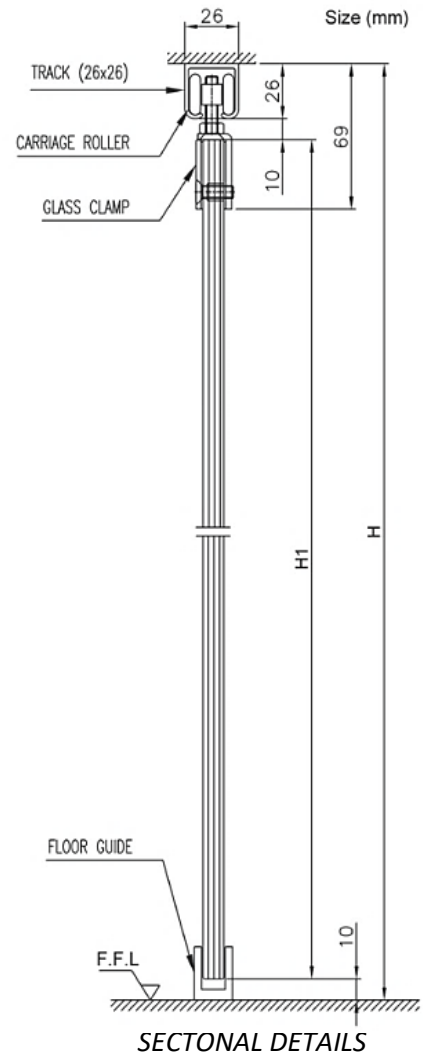

SECTIONAL DETAILS

COMPLETE SET:

1x Aluminum Track 2000mm (RT-040-2000)	2x Carriage Rollers (SDS-040-CR) 2x Glass Clamps (SDS-040-GC)	2x End Stopper (SDS-040-ST) 1x Floor Guide (SDS-040-FG)



SDS-045 SLIDING DOOR GEAR

FEATURES

- For one or more door leaves with or without side panels
- Suitable for 8mm to 12mm thick tempered glass
- Gentle, easy action and no glass preparation
- Maximum weight per door leaf: 45kg

TECHNICAL DRAWINGS:

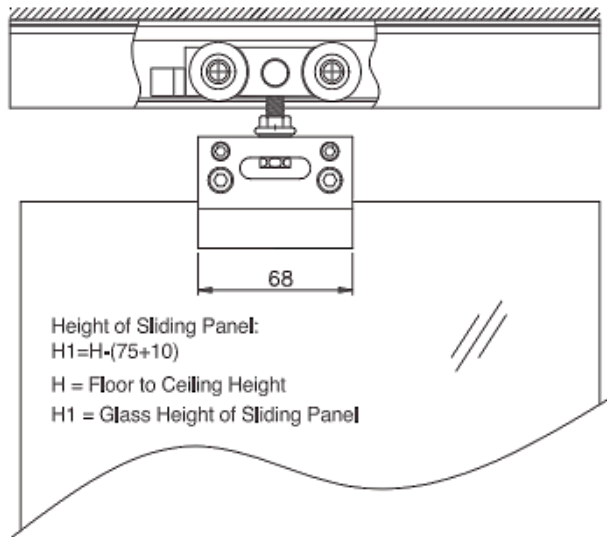

NO GLASS PREPARATION REQUIRED!

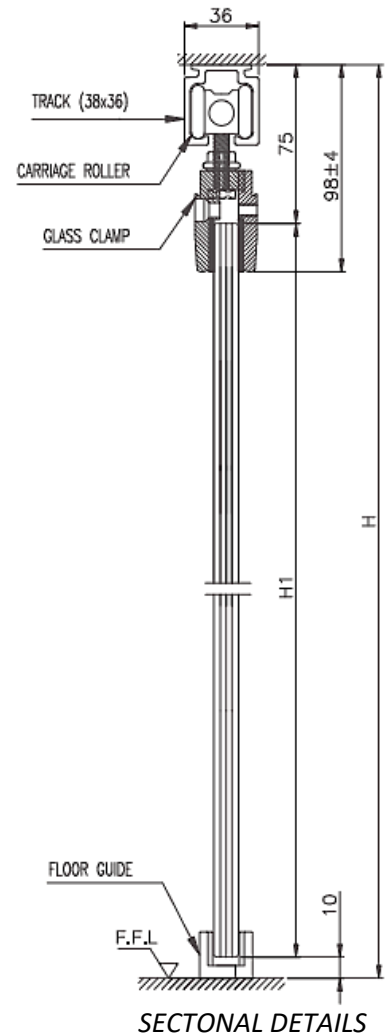

COMPLETE SET:

 1x Aluminum Track 2440mm (RT-1200) 4x Mounting Bracket (MB-120)	 2x Carriage Rollers (SDS-100-CR) 2x Glass Clamps (SDS-045-GC)	 2x End Stopper 1x Floor Guide
--	--	--------------------------------------



SDS-090 SLIDING DOOR GEAR

FEATURES

- For one or more door leaves with or without side panels
- Suitable for 8mm to 12mm thick tempered glass
- Gentle, easy action and no glass preparation
- Maximum weight per door leaf: 90kg

TECHNICAL DRAWINGS:

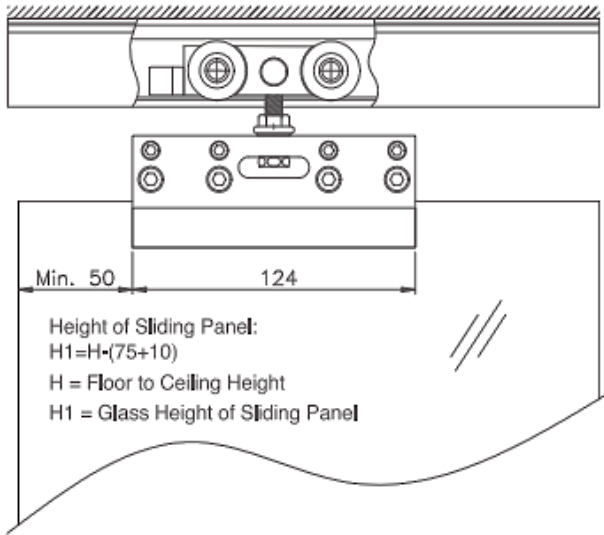

NO GLASS PREPARATION REQUIRED!

PSB Tested for 100,000 cycles endurance

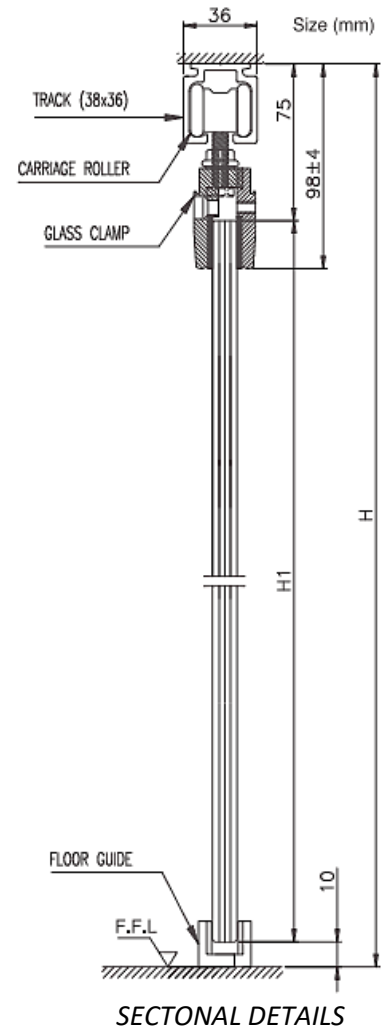

COMPLETE SET:

 <p>1x Aluminum Track 2440mm (RT-1200) 4x Mounting Bracket (MB-120)</p>	 <p>2x Carriage Rollers (SDS-100-CR) 2x Glass Clamps (SDS-090-GC)</p>	 <p>2x End Stopper 1x Floor Guide</p>
--	--	---



SDS-091 SLIDING DOOR GEAR

FEATURES

- For one or more door leaves with or without side panels
- Suitable for 8mm to 10mm thick tempered glass
- Gentle, easy action
- Maximum weight per door leaf: 80kg

TECHNICAL DRAWINGS:

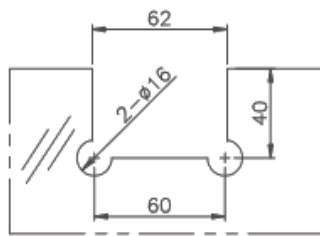
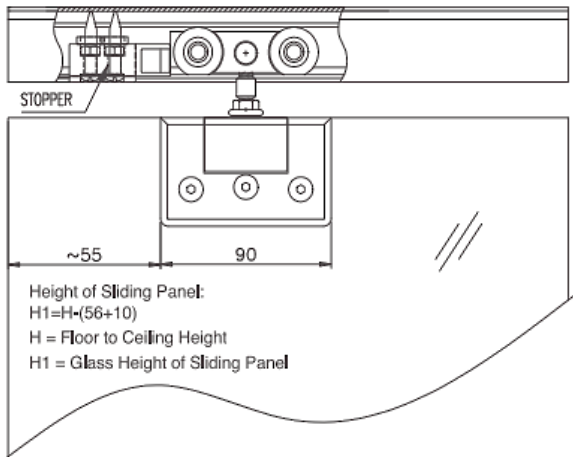

GLASS PREPARATION

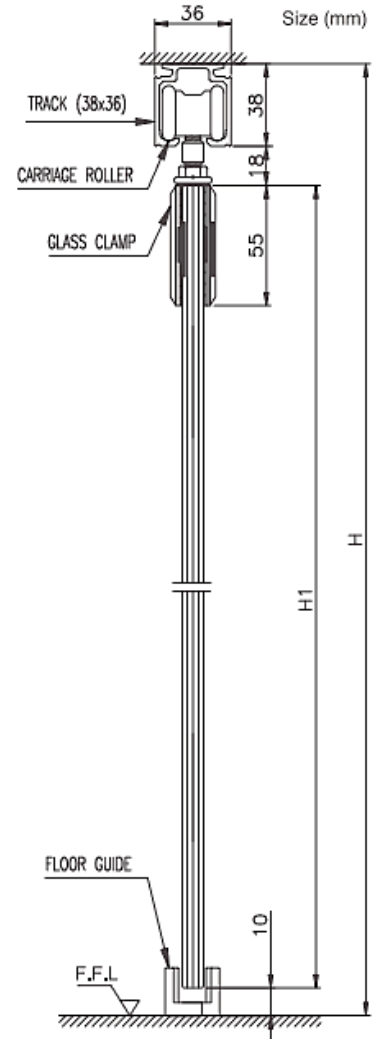

SECTIONAL DETAILS

COMPLETE SET:

 <p>1x Aluminum Track 2440mm (RT-1200) 4x Mounting Bracket (MB-120)</p>	 <p>2x C. Rollers (SDS-091/092-CR) 2x Glass Clamps (SDS-091-GC)</p>	 <p>2x End Stopper 1x Floor Guide</p>
--	---	--



SDS-092 SLIDING DOOR GEAR

FEATURES

- For one or more door leaves with or without side panels
- Suitable for 8mm to 12mm thick tempered glass
- Gentle, easy action
- Maximum weight per door leaf: 80kg

TECHNICAL DRAWINGS:

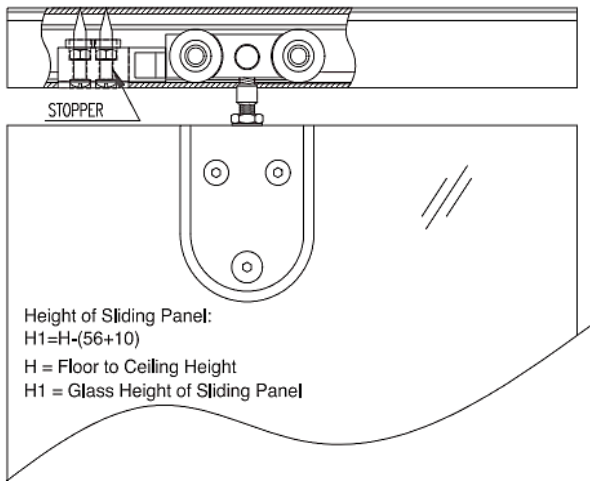

Height of Sliding Panel:
 $H1 = H - (56 + 10)$
 H = Floor to Ceiling Height
 $H1$ = Glass Height of Sliding Panel

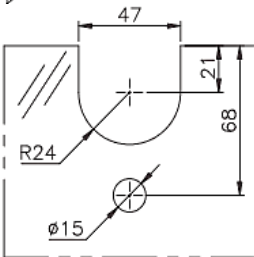

GLASS PREPARATION

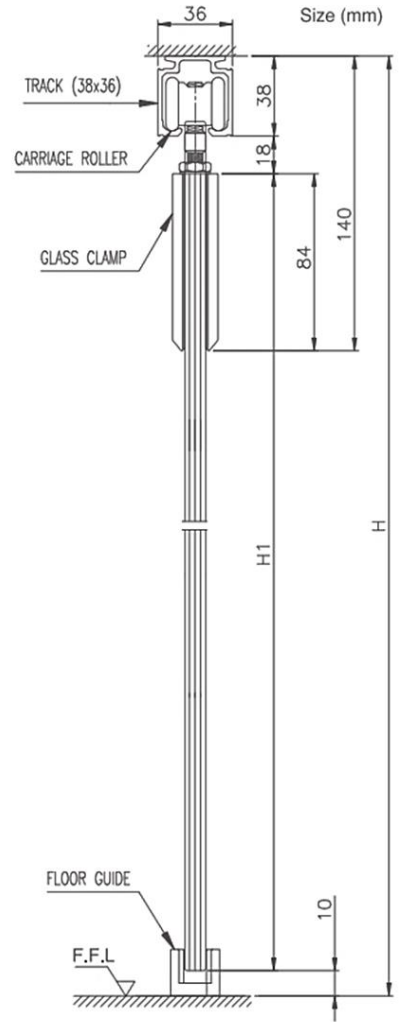

SECTIONAL DETAILS

COMPLETE SET:

 <p>1x Aluminum Track 2440mm (RT-1200) 4x Mounting Bracket (MB-120)</p>	 <p>2x C. Rollers (SDS-091/092-CR) 2x Glass Clamps (SDS-092-GC)</p>	 <p>2x End Stopper 1x Floor Guide</p>
--	--	---



SDS-093 SLIDING DOOR GEAR

(For Wooden Doors)

FEATURES

- Suitable for wooden doors.
- Gentle, easy action
- Maximum weight per door leaf: 90kg

TECHNICAL DRAWINGS:

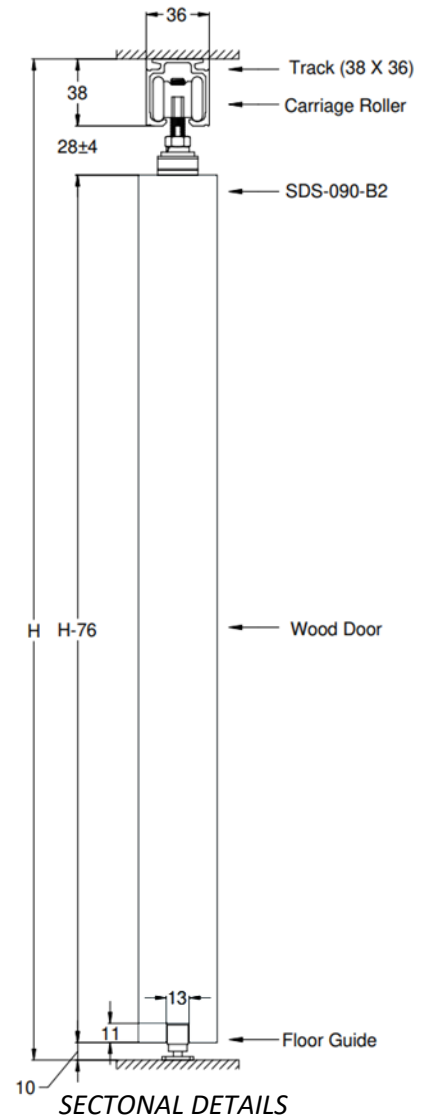
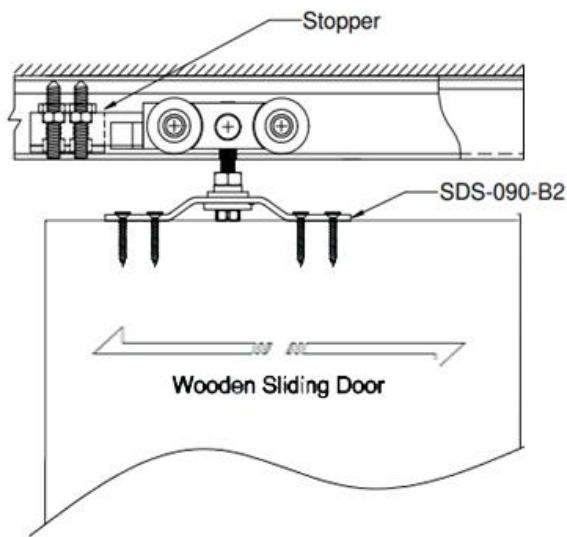

COMPLETE SET:

 1x Aluminum Track 2440mm (RT-1200) 4x Mounting Bracket (MB-120)	 2x Carriage Rollers (SDS-100-CR) 2x Curve Bracket (SDS-090-B2)	 2x End Stopper (SDS-100-ST) 1x Floor Guide (Not Included)
--	---	--

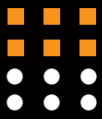

SDS-100 SLIDING DOOR GEAR

FEATURES

- For one or more door leaves with or without side panels
- Suitable for 10mm to 13.52mm thick tempered glass
- Glass preparation is recommended when install on laminated glass
- Gentle, easy action and no glass preparation
- Maximum weight per door leaf: 100kg
- Also available in Black

TECHNICAL DRAWINGS:

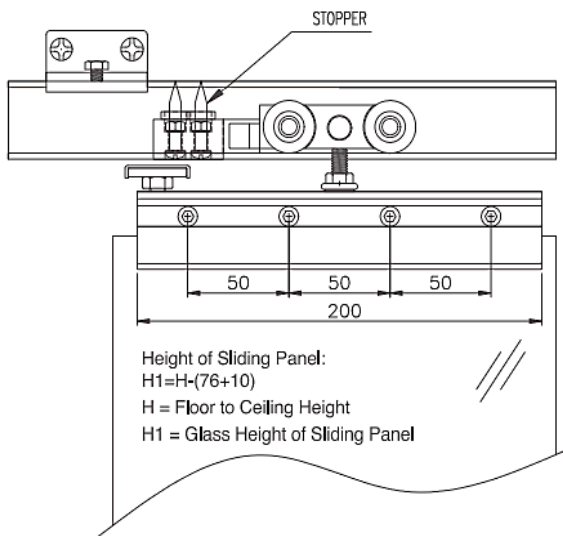

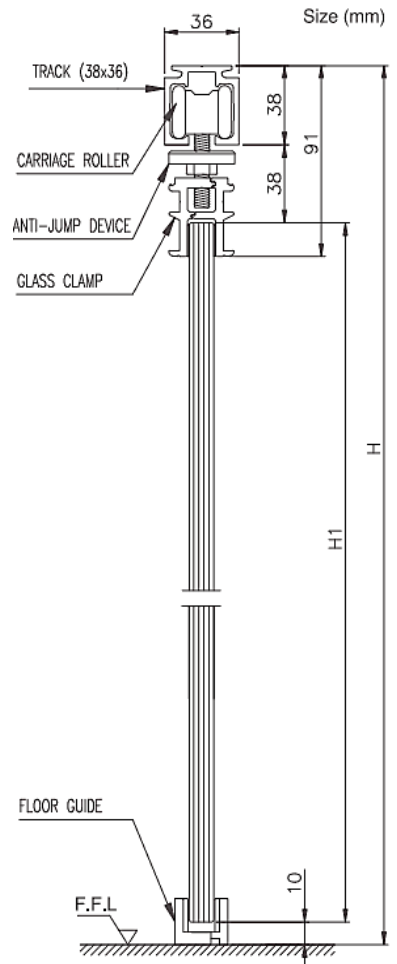

NO GLASS PREPARATION REQUIRED!

PSB Tested for 100,000 cycles endurance



SECTIONAL DETAILS

COMPLETE SET:

 <p>1x Aluminum Track 2440mm (RT-1200) 4x Mounting Bracket (MB-120)</p>	 <p>2x Carriage Rollers (SDS-100-CR) 2x Glass Clamps (SDS-100-GC)</p>	 <p>2x End Stopper 1x Floor Guide</p>
--	--	--



SDS-120 SLIDING DOOR GEAR

FEATURES

- For one or more door leaves with or without side panels
- Suitable for 10mm to 13.52mm thick tempered glass
- Gentle, easy action and no glass preparation
- Glass preparation is recommended when install on laminated glass
- Maximum weight per door leaf: 120kg
- Slanted Track and Roller System, minimizes the trapping of dust
- Also available in Black

TECHNICAL DRAWINGS:

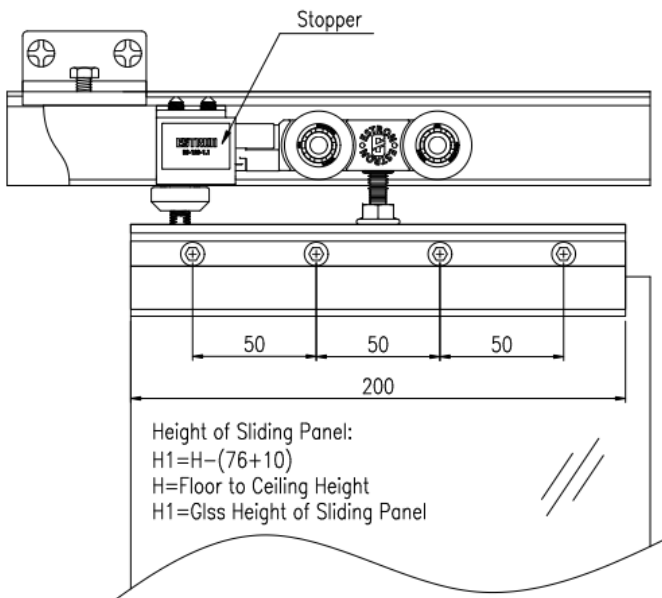

NO GLASS PREPARATION REQUIRED!

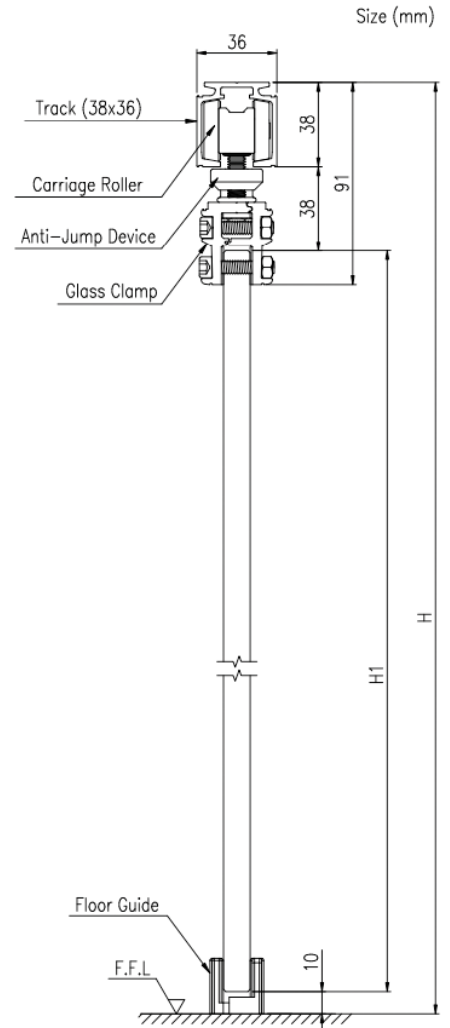

SECTIONAL DETAILS

COMPLETE SET:

 <p>1x Aluminum Track 2440mm (RT-3836) 4x Mounting Bracket (MB-120)</p>	 <p>2x Carriage Rollers (CR-120) 2x Glass Clamps (SDS-100-GC)</p>	 <p>2x End Stopper (RS-120) 1x Floor Guide</p>
--	--	--



SDS-121 SLIDING DOOR GEAR

(For Wooden Doors)

FEATURES

- Suitable for wooden doors.
- Gentle, easy action
- Maximum weight per door leaf: 120kg

TECHNICAL DRAWINGS:

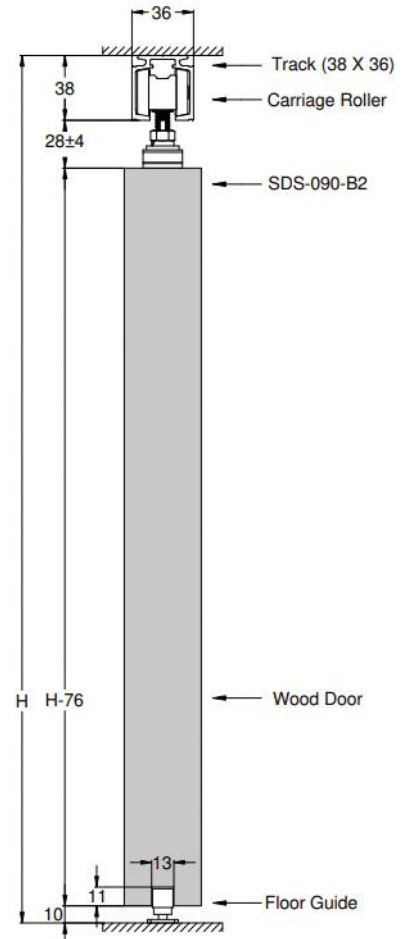
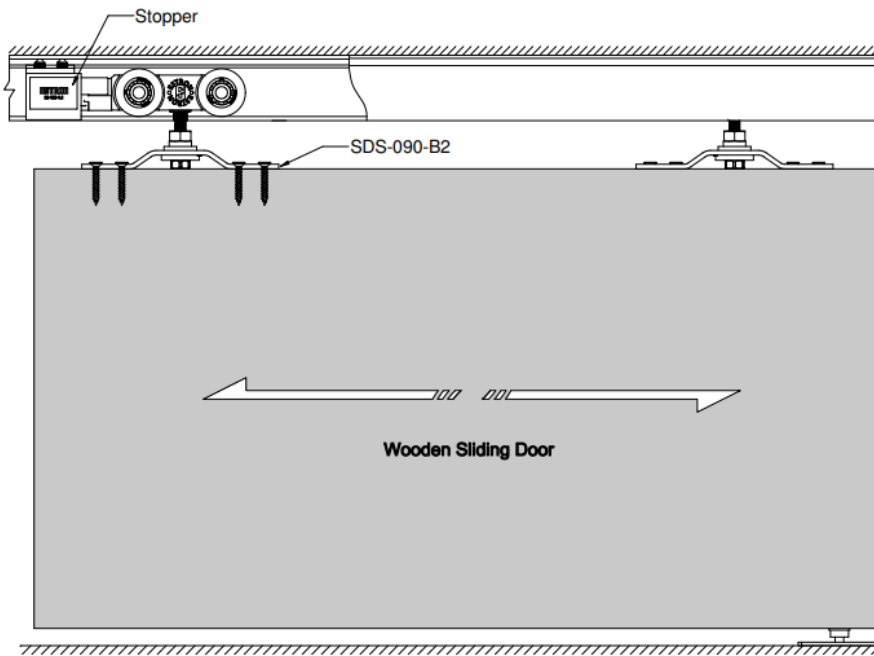

SECTIONAL DETAILS

COMPLETE SET:

		
1x Aluminum Track 2440mm (RT-3836) 4x Mounting Bracket (MB-120)	2x Carriage Rollers (CR-120) 2x Curve Bracket (SDS-090-B2)	2x End Stopper (RS-120) 1x Floor Guide (FG-100)



SDS-120H SLIDING DOOR GEAR

(Heavy Duty)

FEATURES

- For one or more door leaves with or without side panels
- Suitable for 10mm to 13.52mm thick tempered glass
- Maximum weight per door leaf: 120kg
- Stainless Steel Glass Clamp SS304, Satin Finish (SSS)

TECHNICAL DRAWINGS:

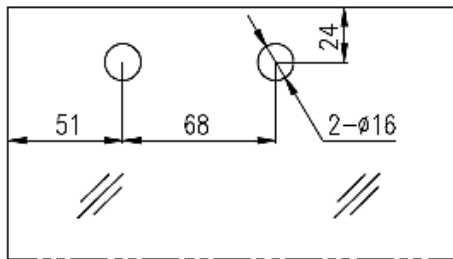
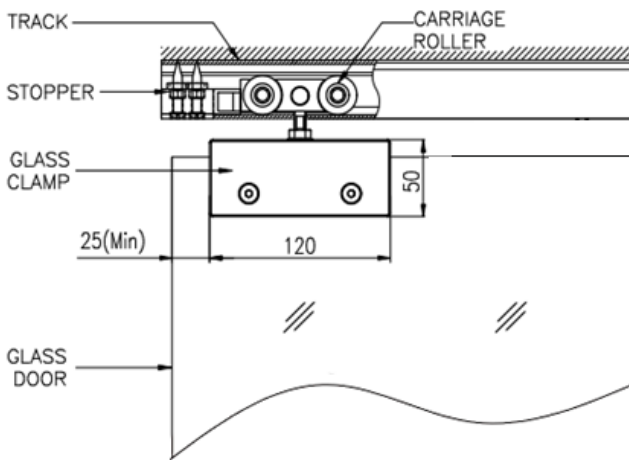

GLASS PREPARATION

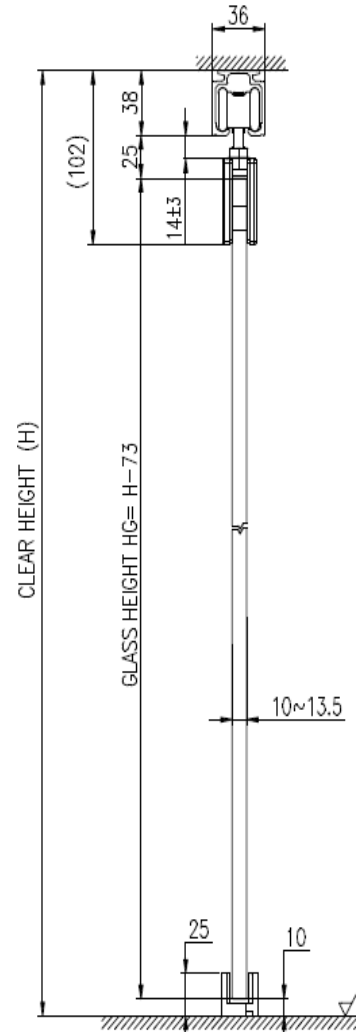

SECTIONAL DETAILS

COMPLETE SET:

 <p>1x Aluminum Track 2440mm (RT-1200) 4x Mounting Bracket (MB-120)</p>	 <p>2x Carriage Rollers (SDS-100-CR) 2x Glass Clamps (SDS-120H-GC)</p>	 <p>2x End Stopper 1x Floor Guide</p>
--	---	---



SDS-150 SLIDING DOOR GEAR

(Heavy Duty)

FEATURES

- For one or more door leaves with or without side panels
- Suitable for 10mm to 15.52mm thick tempered glass
- Gentle, easy action and no glass preparation
- Glass preparation is required for laminated glass installation.
- Maximum weight per door leaf: 150kg

TECHNICAL DRAWINGS:

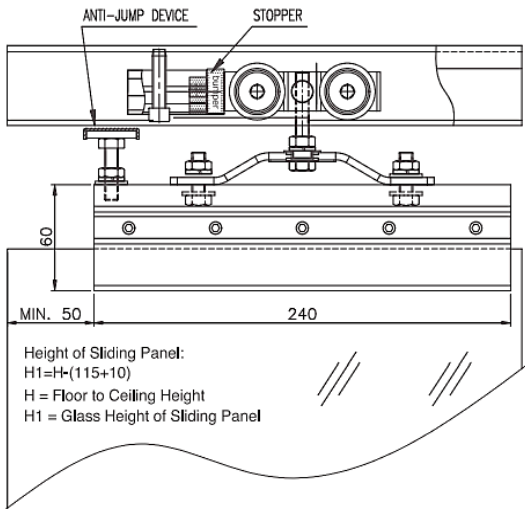

NO GLASS PREPARATION REQUIRED!

PSB Tested for 100,000 cycles endurance

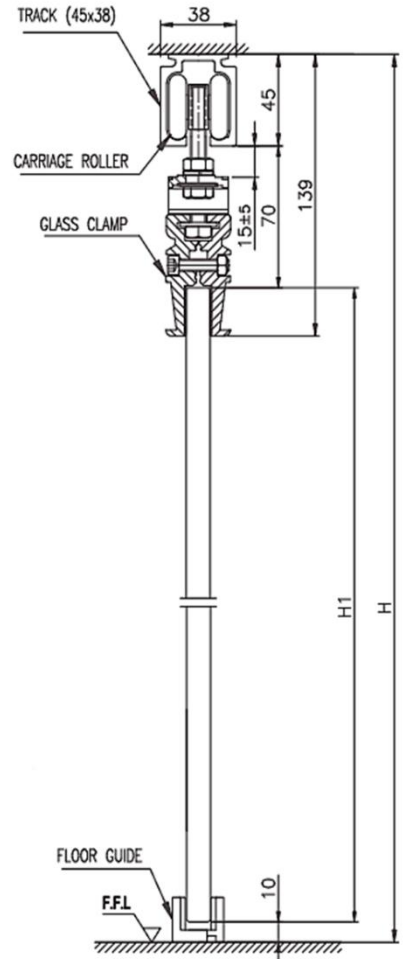

SECTIONAL DETAILS

COMPLETE SET:

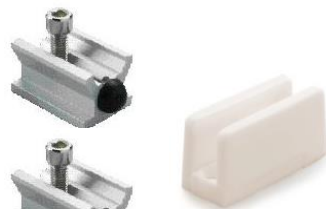
 <p>1x Aluminum Track 3000mm (RT-1500) 4x Mounting Bracket (MB-150)</p>	 <p>2x Carriage Rollers (SDS-150-CR) 2x Glass Clamps (SDS-150-GC)</p>	 <p>2x End Stopper (SDS-150-ST) 1x Floor Guide</p>
--	--	--



SDS-180 SLIDING DOOR GEAR

(Heavy Duty)

FEATURES

- For one or more door leaves with or without side panels
- Suitable for 10mm to 15.52mm thick tempered glass
- Gentle, easy action and no glass preparation
- Glass preparation is required for laminated glass installation.
- Maximum weight per door leaf: 180kg

TECHNICAL DRAWINGS:

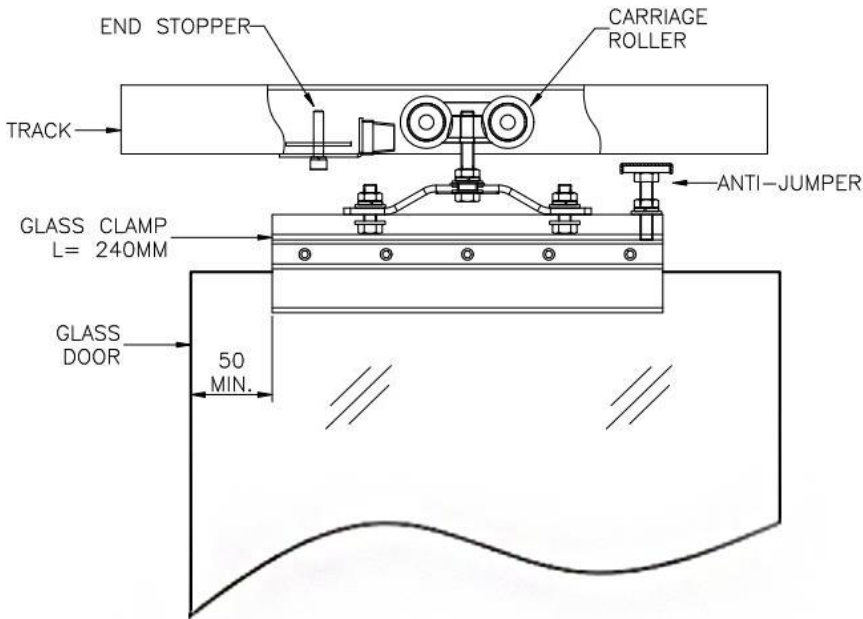

NO GLASS PREPARATION REQUIRED!

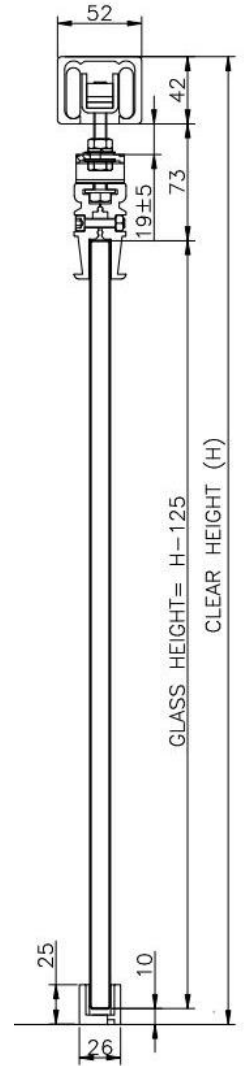

SECTIONAL DETAILS

COMPLETE SET:

 <p>1x Aluminum Track 3000mm (RT-1800)</p>	 <p>2x Carriage Rollers (SDS-180-CR) 2x Glass Clamps (SDS-180-GC)</p>	 <p>2x End Stopper (SDS-180-ST) 1x Floor Guide</p>
---	--	--



SDS-300 SLIDING DOOR GEAR

(Heavy Duty)

FEATURES

- For one or more door leaves with or without side panels
- Suitable for 12mm to 15.52mm thick tempered glass
- Gentle, easy action and no glass preparation
- Glass preparation is recommended for Laminated Glass and glass height of more than 3600mm.
- Maximum weight per door leaf: 300kg

TECHNICAL DRAWINGS:

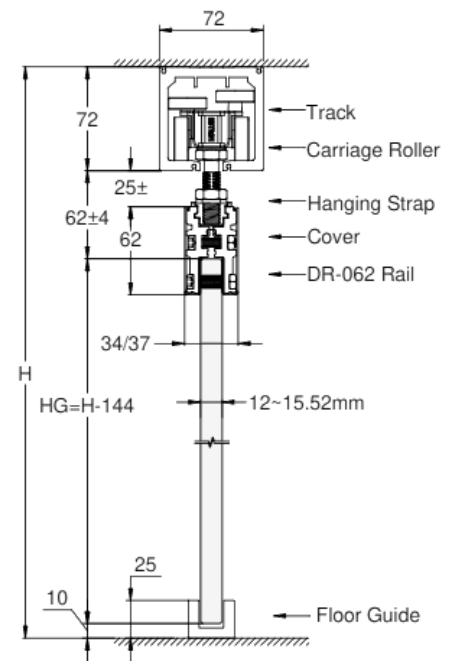
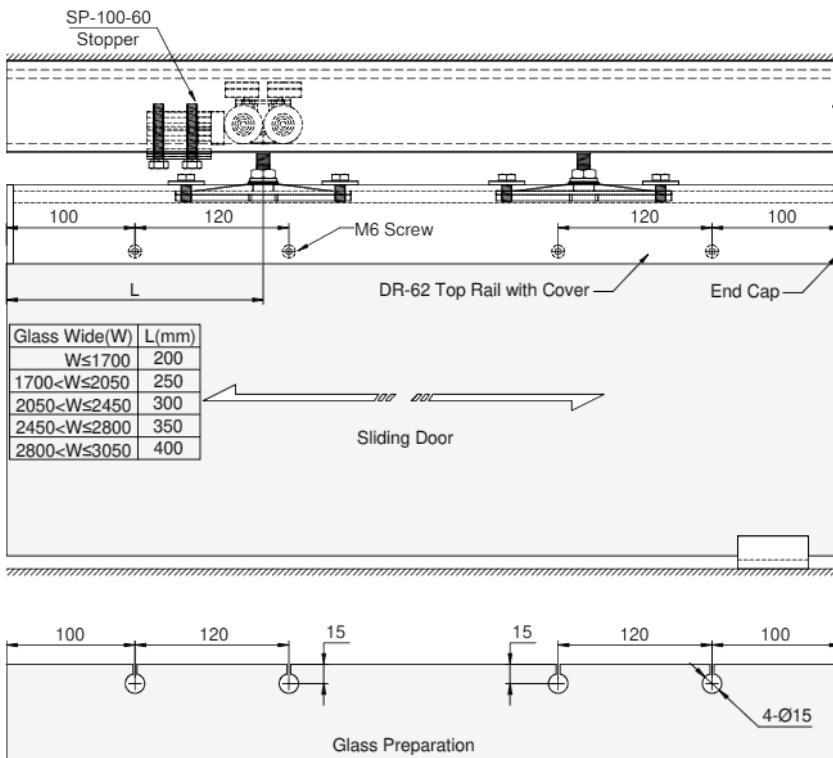

SECTIONAL DETAILS

COMPLETE SET:

 <p>1x Aluminum Track 3000mm (E72)</p>	 <p>2x Carriage Rollers (CR-300.SS) 1x Glass Clamps 3000mm</p>	 <p>2x End Stopper (SP-100-60) 1x Floor Guide</p>
---	---	---

ST-100 SLIDING DOOR GEAR

(Telescopic)

FEATURES

- For one or more door leaves with or without side panels
- Suitable for 10mm to 12mm thick tempered glass
- Gentle, easy action and no glass preparation
- Glass preparation is required for laminated glass installation.
- Maximum weight per door leaf: 100kg

TECHNICAL DRAWINGS:

Glass Clamp Position (With Stopper)

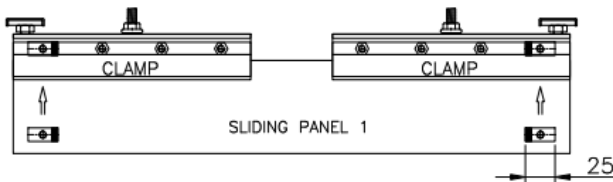

Top View



SLIDING PANEL 1

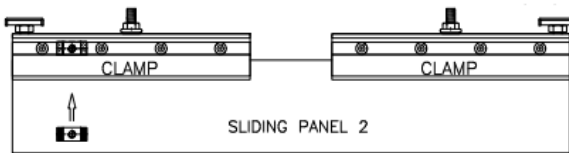

Top View



SLIDING PANEL 2

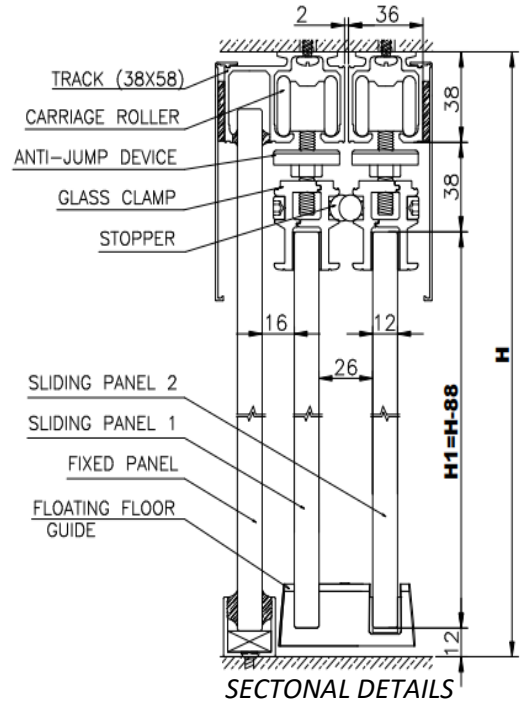

SECTIONAL DETAILS

Accessories shown in above drawing is for reference only.
Cover and Track RT-1220 is not included

Height of Sliding Panel:

$$H1 = H - (76 + 12)$$

H = Floor to Ceiling Height

H1 = Glass Height of Sliding Panel

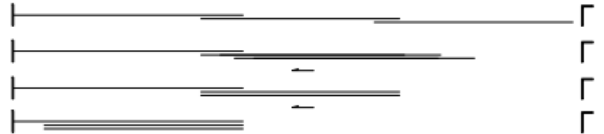

COMPLETE SET:

 <p>2x Aluminum Track 2440mm (RT-1200)</p>	 <p>4x Carriage Rollers (SDS-100-CR) 4x Glass Clamps (SDS-100-GC)</p>	 <p>2x End Stopper (SDS-100-ST) 1x Floor Guide (ST-FG) 3x ST-Gear</p>
---	--	---

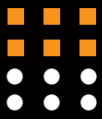

ST-120H SLIDING DOOR GEAR

(Heavy Duty Telescopic)

FEATURES

- For one or more door leaves with or without side panels
- Suitable for 10mm to 12mm thick tempered glass
- Glass preparation depends on different types of layout, please consult us upon ordering.
- Maximum weight per door leaf: 120kg
- Stainless Steel Glass Clamp SS304, Satin Finish (SSS)

TECHNICAL DRAWINGS:

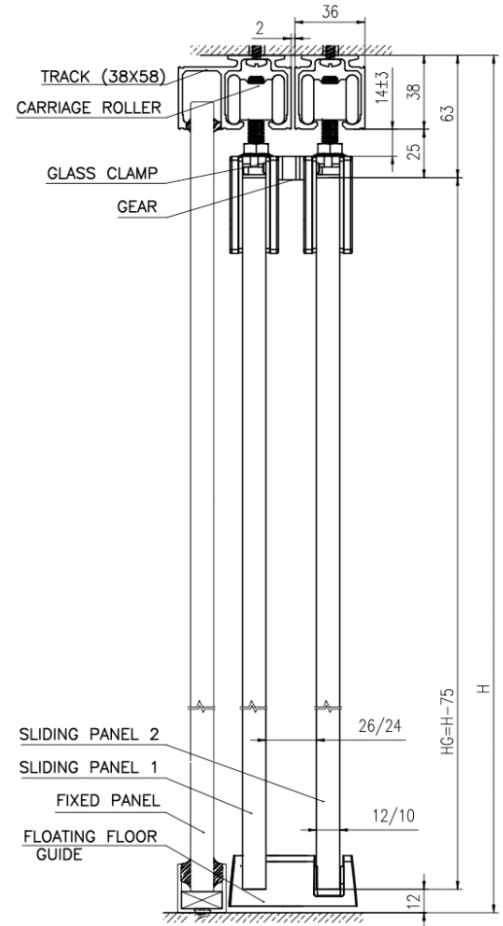
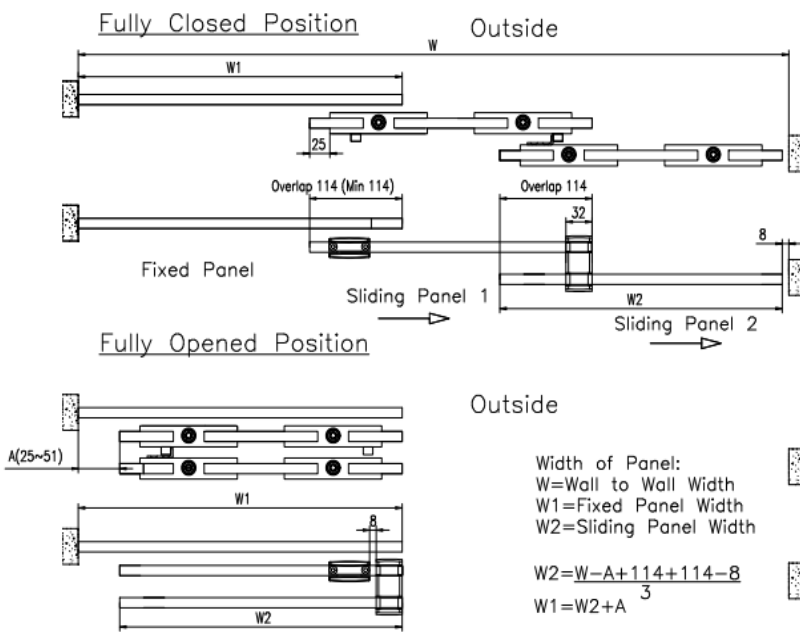

SECTIONAL DETAILS

Accessories shown in above drawing is for reference only. Cover and Track RT-1220 is not included

COMPLETE SET:

 <p>2x Aluminum Track 2440mm (RT-1200)</p>	 <p>4x Carriage Roller (SDS-100-CR) 4x Glass Clamps (SDS-120H-GC)</p>	 <p>2x End Stopper 1x Floor Guide (ST-FG) 3x ST-Gear</p>
---	--	--

ST-150 SLIDING DOOR GEAR

(Heavy Duty Telescopic)

FEATURES

- For one or more door leaves with or without side panels
- Suitable for 10mm to 12mm thick tempered glass
- Gentle, easy action and no glass preparation
- Glass preparation is required for laminated glass installation.
- Maximum weight per door leaf: 150kg

TECHNICAL DRAWINGS:

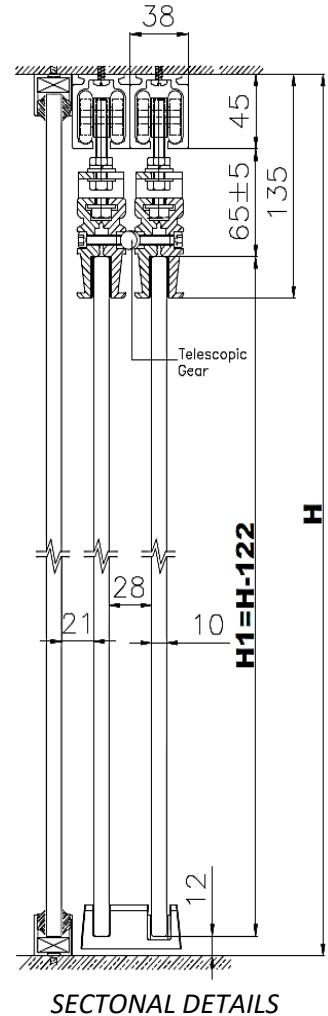
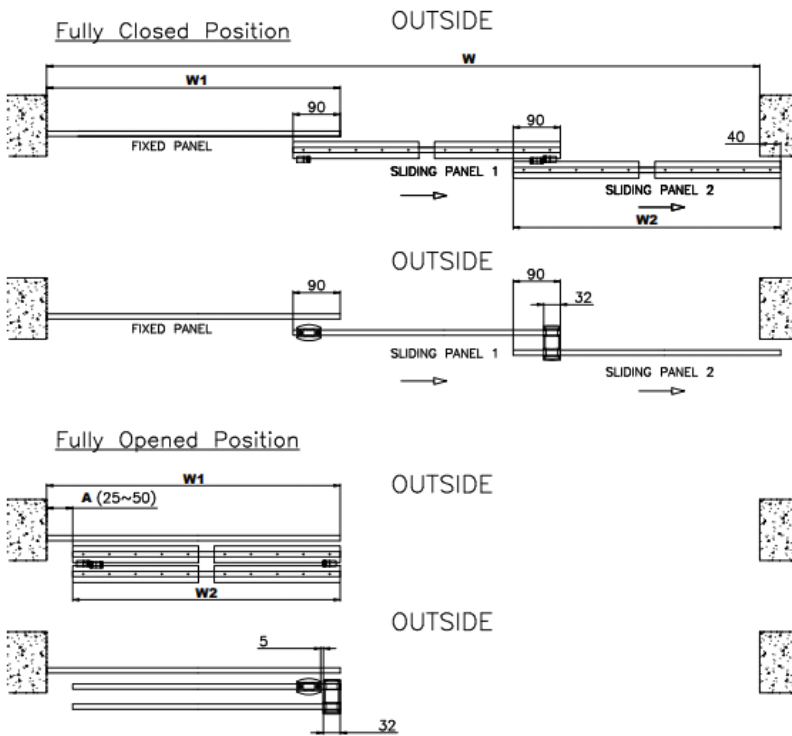

COMPLETE SET:

 <p>2x Aluminum Track 3000mm (RT-1500)</p>	 <p>4x Carriage Roller (SDS-150-CR) 4x Glass Clamps (SDS-150-GC)</p>	 <p>2x End Stopper (SDS-150-ST) 1x Floor Guide (ST-FG) 3x ST-Gear</p>
---	---	---



Estron Marketing Pte. Ltd.

141 Woodlands Industrial Park E5 E-terrace Singapore 757507

tel. +65 6853 9041 fax. +65 6853 9042

e-mail. sales@estron.com.sg url. www.estron.com.sg



*Product improvement is a continuous process,
please check specifications at point of purchase.*